

## Operating manual

Transmitters / regulators

### HD45 – HD46



Companies / Brands of GHM

Members of GHM GROUP

**GREISINGER**

**HONSBURG**

**Martens**

**IMTRON**

**Delta OHM**

Keep for future reference.

## 1. INTRODUCTION

The instruments of the **HD45** and **HD46** series are transmitters, indicators and regulators suitable for measuring and monitoring the following environmental parameters, depending on the model:

- Relative humidity (RH)
- Ambient temperature (T)
- Carbon dioxide (CO<sub>2</sub>)
- Dewpoint Temperature (DP, computed value)

These instruments are designed for ambient air monitoring. Typical applications are air quality analysis in crowded buildings (such as schools, hospitals, auditoriums, work sites, refectories etc). This analysis allows to adjust air conditioning systems (temperature and humidity) and ventilation (air changing/hour) in order to achieve a double target: obtain a good air quality in compliance with the ASHRAE and IMC directives in force and save energy.

RH (Relative Humidity) measurement is obtained by means of a capacitive sensor. The sensor is temperature compensated to assure accurate and reliable measurements with the time. In **HD46** models, relative humidity and temperature sensors with their calibration data are contained in an easy-to-replace module.

The temperature T is measured by means of a high-accuracy NTC sensor.

CO<sub>2</sub> (Carbon Dioxide) measurement is obtained by use of a special infrared sensor (**NDIR** technology: Non-Dispersive Infrared Technology) that ensures long-lasting, accurate and stable measures, thanks to the use of a double filter and a special measurement technique. The presence of a protection membrane, through which sampled air flows, protects the sensor from dust and atmospheric agents.

The instruments are factory calibrated and require no further adjustment by the installer.

The instrument is wall-mounted and sensors are built-in.

**0÷10V voltage or 4÷20mA current analog output** versions are available, along with PC-connectable versions via **RS485** serial port with **MODBUS-RTU** protocol, allowing connection with multiple transmitters on the same network.

**Relay**-equipped versions allow direct monitoring of measured ambient parameters when user-custom thresholds are exceeded. Monitoring activation is shown by LED indicators (in HD46...R models only). The relays operation is very versatile: they are provided with an activation mode when threshold limits (lower/upper limit) are exceeded, and in single or double threshold mode. Thresholds are user-configurable over the whole range.

The LCD display option allows immediate viewing of all instrument-detected measures.

The models **HD45 BVR** and **HD45 BAR** are distinguished by the ability to indicate an immediate level of air quality, through turning on of the LED indicators associated with graphic symbols.

All instrument functions can be set up in a quick and intuitive way through connection to a PC.

**HD46** series models can be provided with a keyboard that allows easy instrument setup even if not connected to a PC. Models provided with keyboard have a display with backlight that can be enabled by a simple key pressure.

Models of the series **HD45** provided with relay have a hardware switch that allows quick selection of the threshold between a set of preset values.

All models perform continuous measure storing and data can be downloaded on a PC.

Instruments are powered with 24Vac or 15...35Vdc supply.

## 1.1 Instruments versions available

### Serie HD45

Model	UR	T	CO <sub>2</sub>	Analog output	RS485 output	Relay output	LCD	Keys	LED
HD45 17V	√	√		√ (2)					Power
HD45 17A	√	√		√ (2)					Power
HD45 17S	√	√			√				Power
HD45 17R	√	√				√ (1)			Power
HD45 17SR	√	√			√	√ (1)			Power
HD45 17VR	√	√		√ (2)		√ (1)			Power
HD45 17AR	√	√		√ (2)		√ (1)			Power
HD45 17DV	√	√		√ (2)			√		Power
HD45 17DA	√	√		√ (2)			√		Power
HD45 17DS	√	√			√		√		Power
HD45 17DR	√	√				√ (1)	√		Power
HD45 17DSR	√	√			√	√ (1)	√		Power
HD45 17DVR	√	√		√ (2)		√ (1)	√		Power
HD45 17DAR	√	√		√ (2)		√ (1)	√		Power
HD45 7BV		√	√	√ (2)					Power
HD45 7BA		√	√	√ (2)					Power
HD45 7BS		√	√		√				Power
HD45 7BR		√	√			√ (1)			Power
HD45 7BSR		√	√		√	√ (1)			Power
HD45 7BVR		√	√	√ (2)		√ (1)			Power
HD45 7BAR		√	√	√ (2)		√ (1)			Power
HD45 7BDV		√	√	√ (2)			√		Power
HD45 7BDA		√	√	√ (2)			√		Power
HD45 7BDS		√	√		√		√		Power
HD45 7BDR		√	√			√ (1)	√		Power
HD45 7BDSR		√	√		√	√ (1)	√		Power
HD45 7BDVR		√	√	√ (2)		√ (1)	√		Power
HD45 7BDAR		√	√	√ (2)		√ (1)	√		Power
HD45 BV			√	√ (1)					Power
HD45 BA			√	√ (1)					Power
HD45 BS			√		√				Power
HD45 BR			√			√ (1)			Power
HD45 BSR			√		√	√ (1)			Power
HD45 BVR			√	√ (1)		√ (1)			<b>4 LED CO<sub>2</sub> level</b>
HD45 BAR			√	√ (1)		√ (1)			<b>4 LED CO<sub>2</sub> level</b>
HD45 BDV			√	√ (1)			√		Power
HD45 BDA			√	√ (1)			√		Power
HD45 BDS			√		√		√		Power
HD45 BDR			√			√ (1)	√		Power
HD45 BDSR			√		√	√ (1)	√		Power
HD45 BDVR			√	√ (1)		√ (1)	√		Power
HD45 BDAR			√	√ (1)		√ (1)	√		Power

## Serie HD46

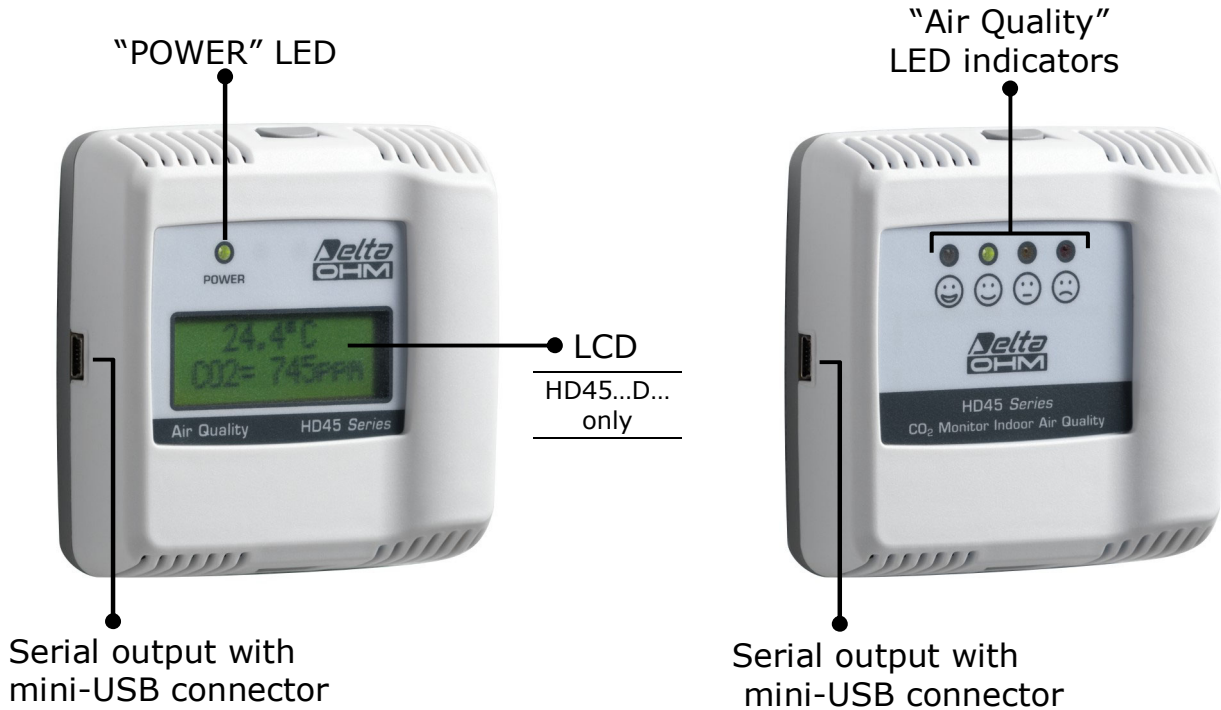
Model	UR	T	CO <sub>2</sub>	Analog output	RS485 output	Relay output	LCD	Keys	LED
HD46 17V	√	√		√ (2)					Power
HD46 17A	√	√		√ (2)					Power
HD46 17S	√	√			√				Power
HD46 17R	√	√				√ (2)			Power RH,T
HD46 17SR	√	√			√	√ (2)			Power RH,T
HD46 17DV	√	√		√ (2)			√		Power
HD46 17DA	√	√		√ (2)			√		Power
HD46 17DS	√	√			√		√		Power
HD46 17DTR	√	√				√ (2)	√	√	Power RH,T
HD46 17DTSR	√	√			√	√ (2)	√	√	Power RH,T
HD46 17BV	√	√	√	√ (3)					Power
HD46 17BA	√	√	√	√ (3)					Power
HD46 17BS	√	√	√		√				Power
HD46 17BR	√	√	√			√ (3)			Power RH,T,CO <sub>2</sub>
HD46 17BSR	√	√	√		√	√ (3)			Power RH,T,CO <sub>2</sub>
HD46 17BDV	√	√	√	√ (3)			√		Power
HD46 17BDA	√	√	√	√ (3)			√		Power
HD46 17BDS	√	√	√		√		√		Power
HD46 17BDTR	√	√	√			√ (3)	√	√	Power RH,T,CO <sub>2</sub>
HD46 17BDTSR	√	√	√		√	√ (3)	√	√	Power RH,T,CO <sub>2</sub>

In the "Analog output" and "Relay output" columns, the number of the available outputs is indicated in brackets.

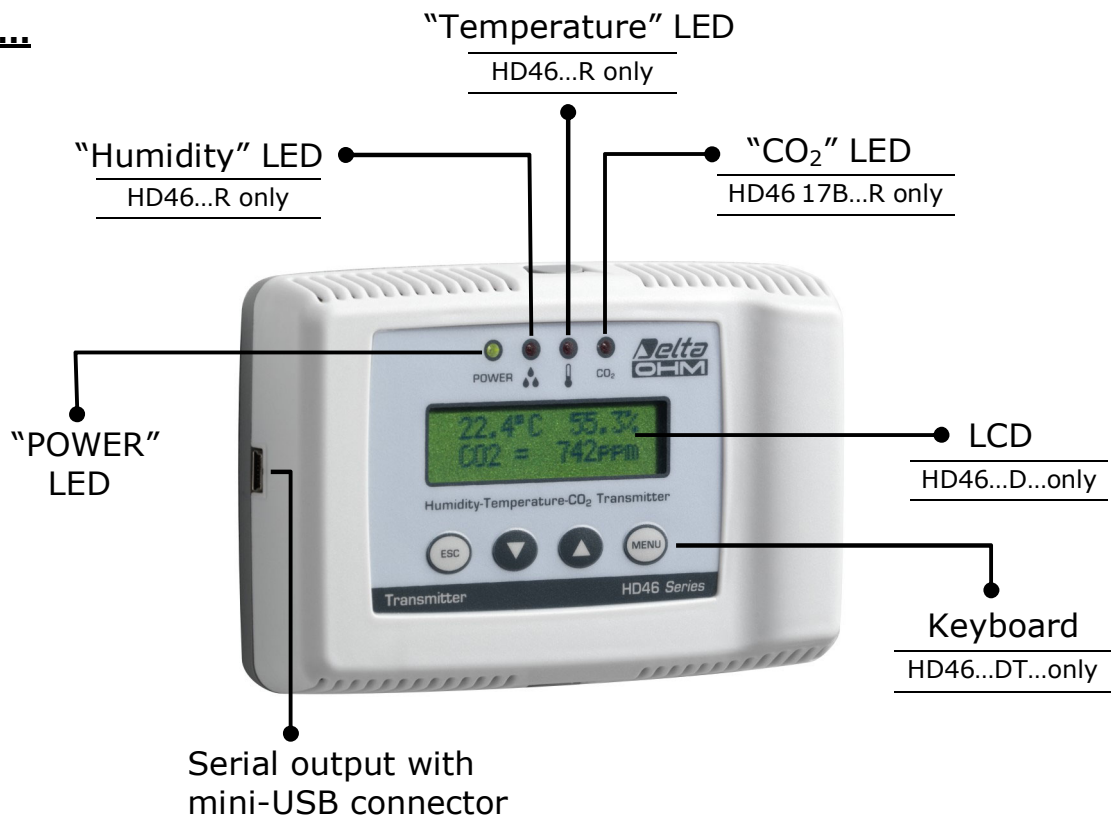
## 2. FRONT PANEL DESCRIPTION

### HD45... (except for HD45 BVR and HD45 BAR)

### HD45 BVR and HD45 BAR



### HD46...



## "POWER" LED

Indicates power supply state. In models without display, it flashes if a fault occurs.

## LCD Display

It simultaneously displays all values measured by the instrument.

## LED level indicators

They show air quality level. In HD45 BVR and HD45 BAR models only.

## "Humidity" LED



It indicates when the set humidity threshold limits are exceeded and the humidity relay is activated. It flashes if an error condition occurs in the humidity measurement.

## "Temperature" LED



It shows when the set temperature threshold limits are exceeded and the temperature relay is activated. It flashes if an error condition occurs in the temperature measurement.

## "CO<sub>2</sub>" LED



It shows when the set CO<sub>2</sub> threshold limits are exceeded and the CO<sub>2</sub> relay is activated. It flashes if an error condition occurs in the CO<sub>2</sub> measurement.

## Keyboard

It allows setting of instrument setup parameters and display backlight activation.



**MENU** key

Accesses setup menu. Confirms set value.



**ESC** key

Exits parameter setting mode. Deletes not confirmed changes.



**ARROW UP** key

Scrolls through parameter list. Increments selected parameter value.



**ARROW DOWN** key

Scrolls through parameter list. Decrements selected parameter value.

## Serial output with mini-USB connector.

Included in all models, it allows connection to a PC for instrument configuration. Connection is obtained via the **RS45** (not isolated) or **RS45I** (isolated) special cable, which has a mini-USB connector for the instrument and a USB connector for a PC. With the **RS45** cable, the instrument is directly powered through a PC's USB port (at least a 500 mA USB port is required). The special cable has a built-in USB adaptor.

*Attention:* the instrument must not be directly connected to your PC by means of a standard mini-USB/USB adaptor cable, but with a **RS45** or **RS45I** cable only.

### 3. INSTALLATION AND CONNECTION

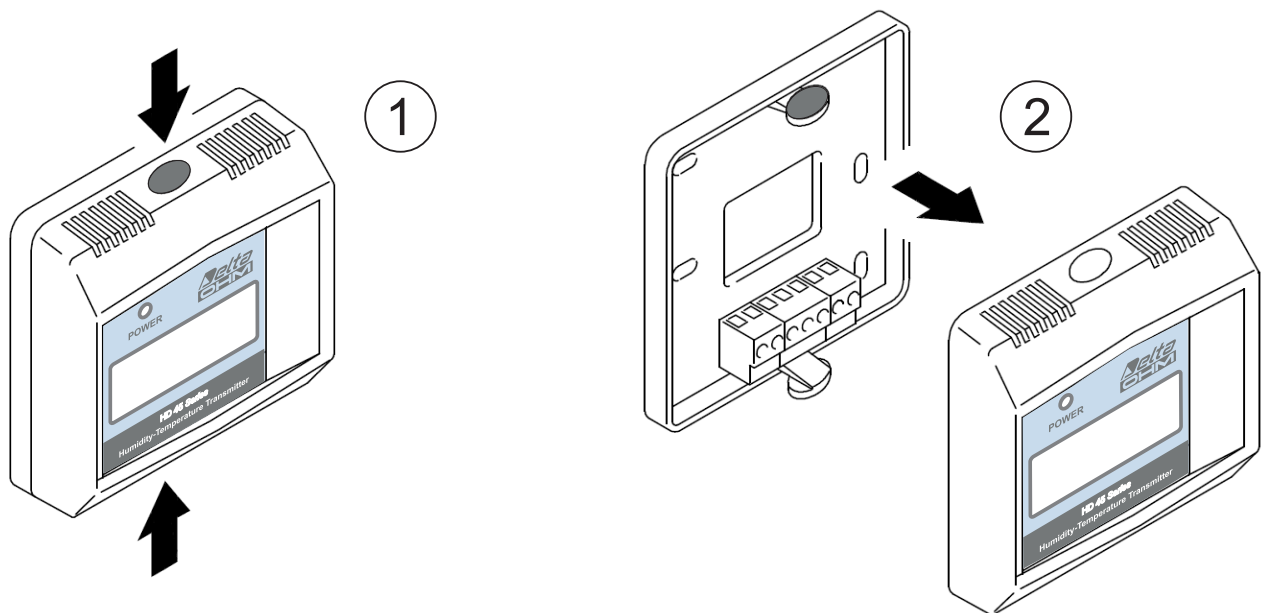
The choice of the number of transmitters to be used for a typical installation and their location depends on multiple factors, among which the dimensions of the breathing space to be monitored, the distribution of people in the environment and the presence of a forced air system.

The transmitter shall be placed in an area which is representative of the environmental conditions, at 1.5m height above the floor and at least 1m distance from the corners.

Do not install the transmitter next to windows, outside doors, direct heat, air conditioning or within occupants' breathing zone.

In all models, sensors and electronics are housed inside a robust plastic case. The grids at the bottom and top of the housing allow ambient air to reach the internal sensitive elements.

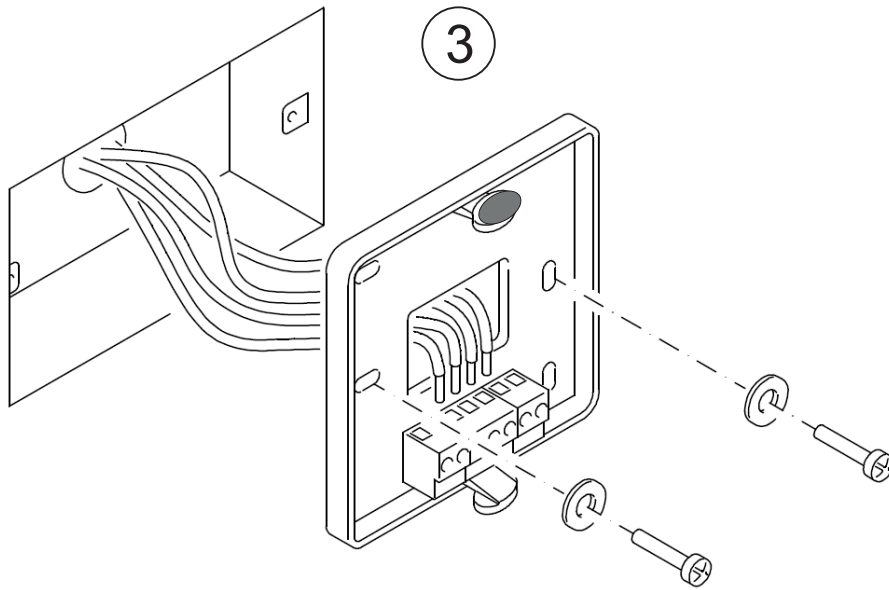
To install the instrument, open the housing by pushing down the upper and lower tabs, then pull to remove the front panel (Fig. 3.A).



**Fig. 3.A: Opening the instrument**

When opening the lid, you will see the holes for fixing the base of the transmitter directly to a panel or to a wall. Fix the base so that connectors are positioned at the bottom of the instrument, and slot matches the connection cable output (Fig. 3.B).

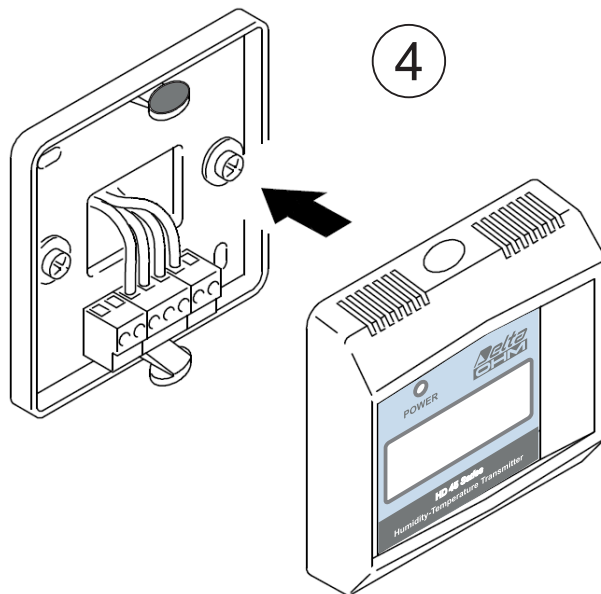




**Fig. 3.B: Fixing the instrument base**

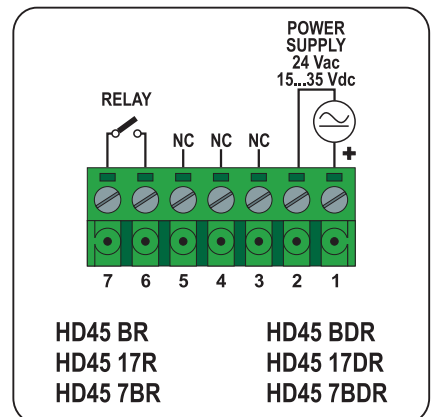
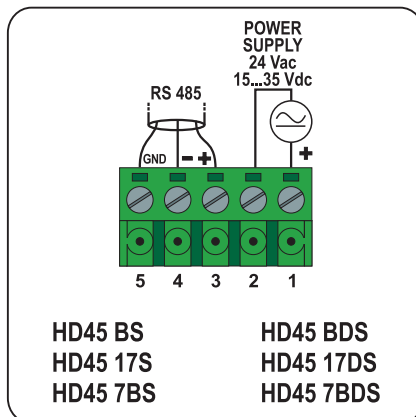
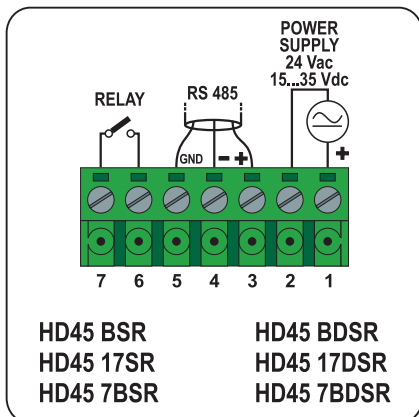
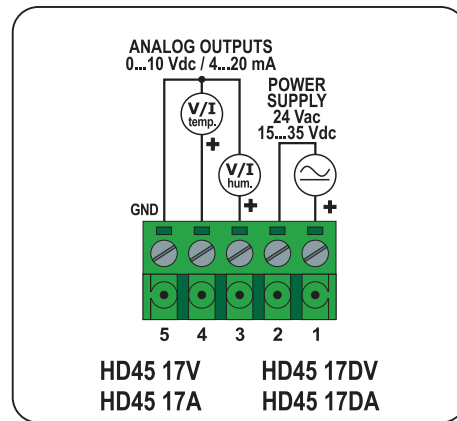
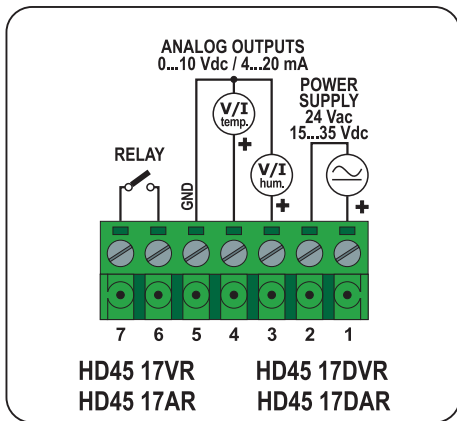
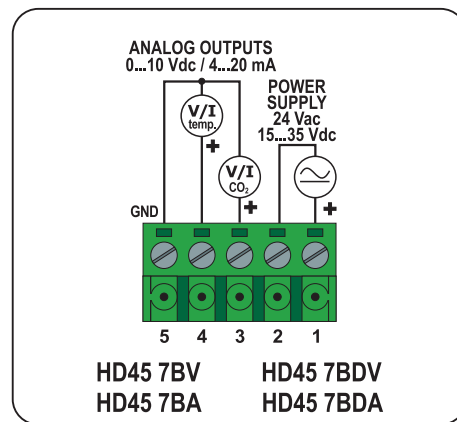
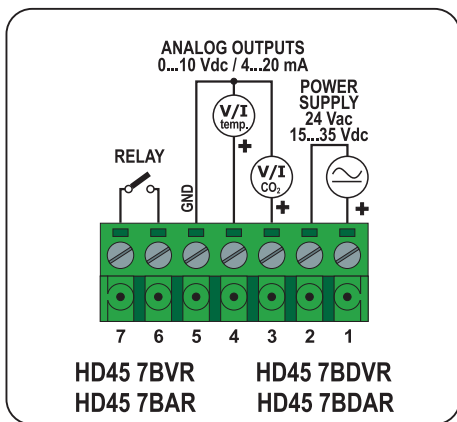
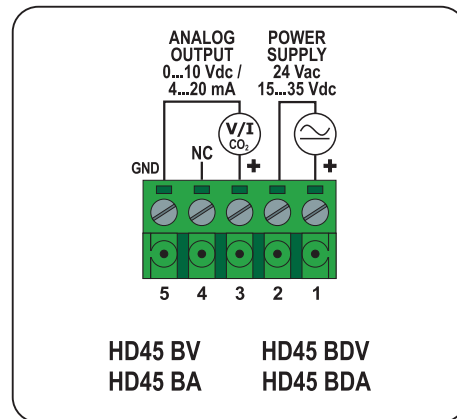
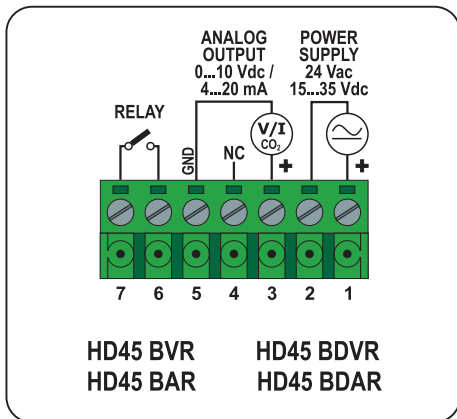
After fixing the base, proceed with the connection of the transmitter as shown in the connection diagrams below. In order to make connection procedures easier, the connection diagram of each model is impressed also at the interior of the base.

Once the connection procedure is completed, put the front panel in place again, making sure that the upper and lower tabs are correctly inserted in their slots (Fig. 3.C).

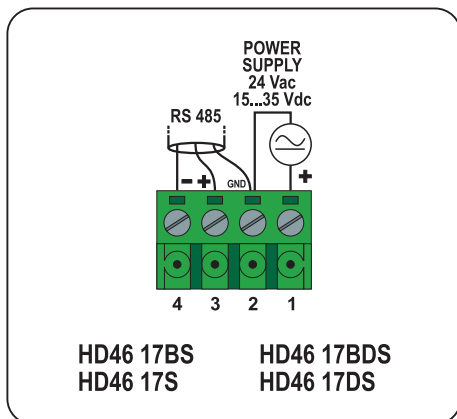
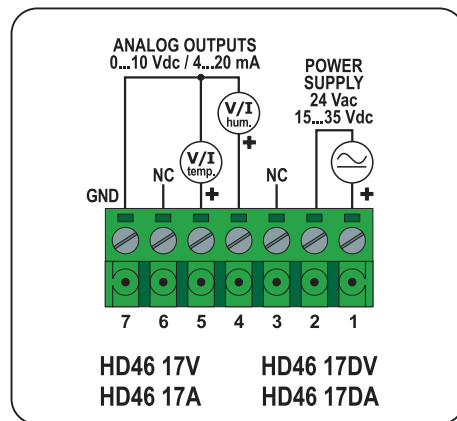
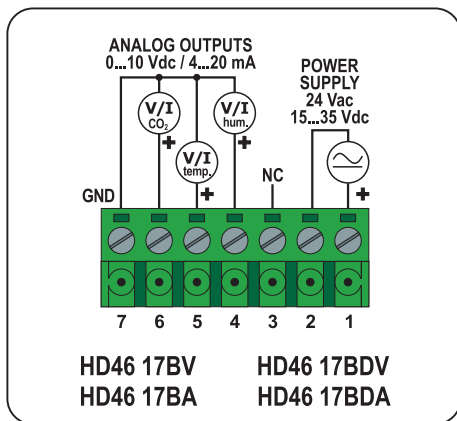
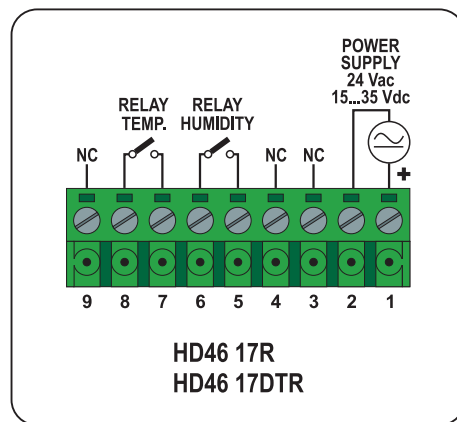
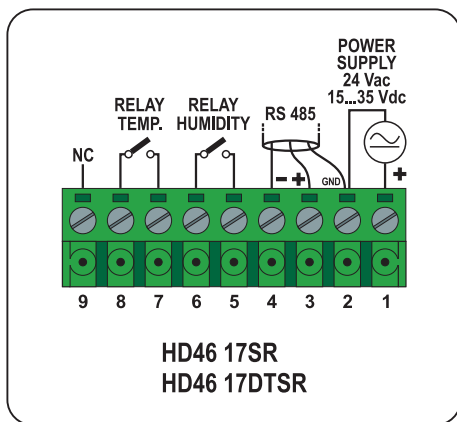
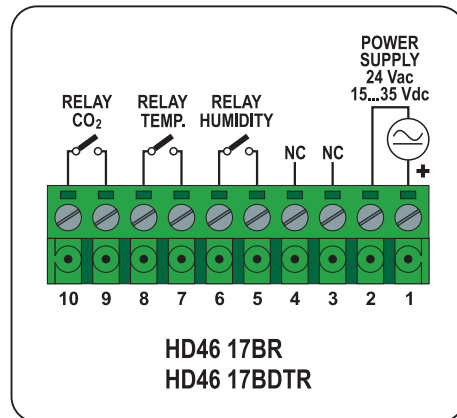
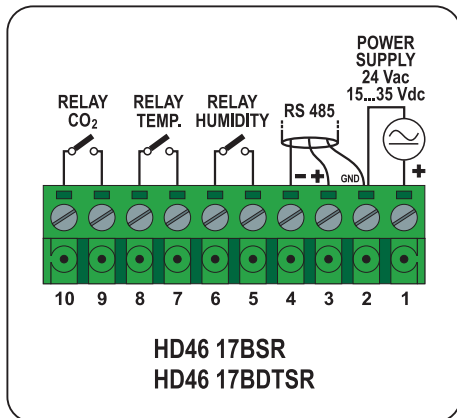


**Fig. 3.C: Closing the instrument**

### 3.1 HD45... connection diagrams



### 3.2 HD46... connection diagrams

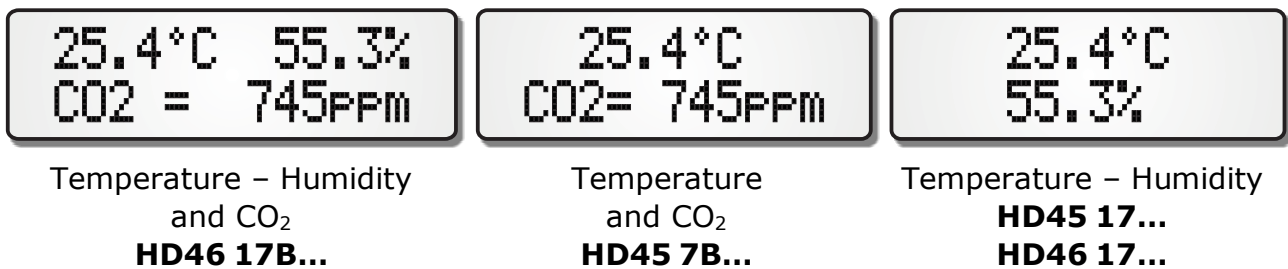


## 4. OPERATION MODE

After installing and connecting the transmitter as shown in section INSTALLATION AND CONNECTION, supply the instrument with the correct voltage. **A wrong power supply may cause permanent damage to the instrument.**

“POWER” LED activation indicates that the instrument is being powered.

In models provided with a display, the indication of the transmitter model and firmware version are displayed and, after a few seconds, measures are shown. The instruments display all measured values simultaneously.



**Fig. 4.A: Viewing measures in models with a display**

Models are preset to display temperature in °C and relative humidity in %. You can setup instruments to display temperature in °F and humidity as dewpoint.



**Fig. 4.B: Viewing humidity as dewpoint**

The instrument requires about 15 minutes to ensure stable measures and indicated accuracy.

In models provided with a keyboard, you can turn on the display backlight by pressing any key. Backlight turns off after 30 minutes of keyboard inactivity.

The instruments are factory preset to be immediately operative. The user can easily customize the configuration of the instrument by connecting it to a PC or by means of the front keyboard, for instruments supplied with a keyboard. For details on configuration, see section “CONFIGURATION”.

The instruments are preset to operate in still air (< 0.25 m/s). To operate in circulating air (e.g. in a climatic room), the operating mode of the instruments must be changed (see the commands Cu0 and Cu1 on pag. 39).

## 4.1 Analog outputs

**HD45...V...**, **HD45...A...**, **HD46...V** and **HD46...A** models have an analog voltage or active current output for each measured value on the instrument. The output range default value is 0...10V (for V models) or 4...20mA (for A models), and default correspondence between output and range is as follows:

**Tab. 4.A: Default settings for analog outputs**

Temperature output	Humidity output	CO <sub>2</sub> output
0V or 4mA = -20.0 °C	0V or 4mA = 0.0 %	0V or 4mA = 0
10V or 20mA = 80.0 °C	10V or 20mA = 100.0 %	10V or 20mA = 5000 ppm

Each output can be configured so as to make the output scale corresponding to a preset range interval.

You can reverse the output operation, in order to make the output value decrease when the measured value increases. You can also add or remove an offset to the output minimum value in order to obtain 2...10Vdc or 0...20mA range.

For the configuration mode, see section "CONFIGURATION".

**In case of measure out of the set interval, the analog output remains fixed to the extreme value if the measure is just a little out, and it becomes 11Vdc or 22mA if the measures is too over or under-range.**

For a correct operation, **please follow the load resistance specifications for the analog outputs indicated in the technical data.**

## 4.2 Relay outputs

**HD45...R** models have only one relay output, that can be associated to one of the quantities measured by the instrument. The **potential free** contact output is preset to close when the measure exceeds the threshold limit.

In **HD46...R** models, each quantity measured by the instrument is associated to a relay output. Relay activation is indicated by the turning on of the corresponding LED situated in the instrument front panel. The **potential free** contact output is preset to close when the measure exceeds the threshold limit for CO<sub>2</sub> and humidity, and to close when the measure falls below the threshold limit for temperature.

Thresholds and hysteresis can be configured. Relays can operate in various modes, with one or two thresholds. Each relay output can be configured to operate differently from the others. The relay contact can also be set to close when an error occurs concerning a measured quantity, for example in case of a sensor fault or of an over range measure. For the relay configuration mode, see section "CONFIGURATION".

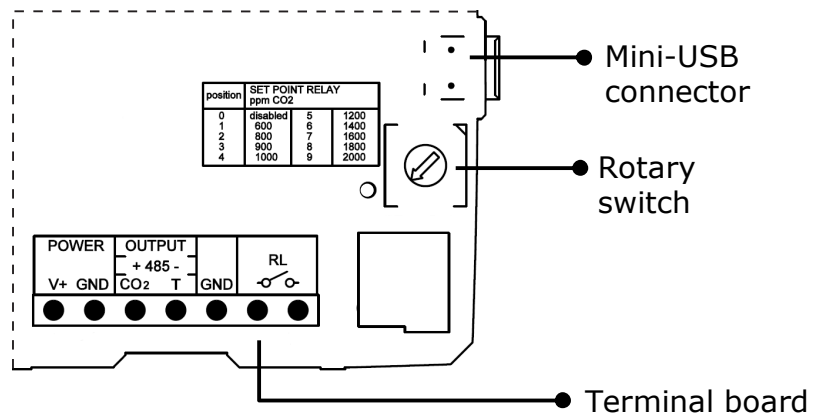
The employed relays are **bistable**, so there isn't a rest state. **In case of no power supply, the relay contact holds its last set position.**

### Relay output in HD45...R models

In **HD45 17...R** and **HD45 7B...R** models, the relay is factory associated with temperature while, in **HD45 B...R**, it is associated with CO<sub>2</sub> measurement. The relay can be used in two modes:

- *Simplified mode*: the relay functions with a single threshold, that can be selected from a series of fixed values via a rotary switch.
- *Complete mode*: the relay may function with one or two thresholds that can be freely set via a PC.

Toggleing between the two modes is made by means of a rotary selector placed on the instrument electric board, between the terminal board and the mini-USB connector.



**Fig. 4.C: Rotary selector position**

The selector has ten numbered positions ranging from 0 to 9.

If the selector is in position 0 (default setting), we are in *complete* mode and the instrument operates with thresholds and hysteresis set via software (see Tab. 4.B for factory settings).

**Tab. 4.B: Relay output default settings in HD45 models**

Temperature (HD45 17...R and HD45 7B...R)	CO <sub>2</sub> (HD45 B...R)
Threshold = 100.0 °C	Threshold = 1000 ppm
Hysteresis = 5.0 °C	Hysteresis = 100 ppm

If the selector is in a position other than zero, we are in *simplified* mode: the relay activates only on the threshold set with the rotary selector.

If the selector is associated with the CO<sub>2</sub> measurement, each position corresponds to a threshold value according to the table below:

**Tab. 4.C: CO<sub>2</sub> threshold rotary selector**

POSITION	CO <sub>2</sub> RELAY THRESHOLD (ppm)
0	Rotary selector disabled
1	600
2	800
3	900
4	1000
5	1200
6	1400
7	1600
8	1800
9	2000

If the selector is in a position other than zero, hysteresis is preset to 100 ppm. Hysteresis and intervention mode can be changed via software (see section "CONFIGURATION"). Please note, however, that hysteresis and intervention mode with the rotary selector in zero position differ from hysteresis and intervention mode with the rotary selector in position other than zero.

If the relay is associated with temperature, the selector is preset as follows:

**Tab. 4.D: Default settings for temperature selector**

POSITION	TEMPERATURE RELAY THRESHOLD (°C)
0	Rotary selector disabled
1	18.0
2	23.0
3	28.0
4	33.0
5	38.0
6	43.0
7	48.0
8	53.0
9	58.0

Hysteresis is preset to 5.0°C and can be modified. Either threshold 1 value and the interval between subsequent positions can be changed. For settings, see section "CONFIGURATION".

### **Relay outputs in HD46...R models**

In **HD46...R** models as well, the relay can be used in two modes:

- *Simplified mode*: relays operate with a single, freely settable threshold; if the instrument is supplied with a keyboard, it has a threshold quick setting mode.
- *Complete mode*: relays can operate with one or two thresholds, the quick setting mode is disabled.

The instrument is preset in complete mode with the following thresholds:

**Tab. 4.E: Relay output default settings in HD46 models (complete mode)**

Temperature	Humidity	CO <sub>2</sub>
Threshold = 20.0 °C	Threshold = 50.0 %	Threshold = 1000 ppm
Hysteresis = 5.0 °C	Hysteresis = 5.0 %	Hysteresis = 100 ppm

If the simplified mode is enabled, the preset thresholds will be as follows:

**Tab. 4.F: Relay output default settings in HD46 models (simplified mode)**

Temperature	Humidity	CO <sub>2</sub>
Threshold = 21.0 °C	Threshold = 50.0 %	Threshold = 800 ppm
Hysteresis = 5.0 °C	Hysteresis = 5.0 %	Hysteresis = 100 ppm

Please note that thresholds and relay operation modes in simplified mode differ from thresholds and relay operation modes in complete mode, see section "CONFIGURATION".

In simplified mode, if the instrument is supplied with display and keyboard, thresholds can easily be viewed and changed by pressing the **MENU** key (for least than 2 seconds).



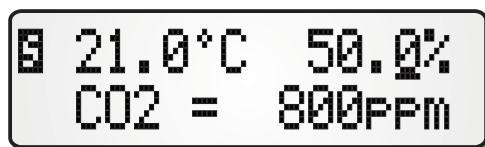
The threshold values of the quantities measured by the instrument are shown on the display. The **S** symbol on top left of the display indicates that you are in the threshold values screen. A full flashing cursor appears next to one of the available thresholds.

Thresholds can be changed as follows:

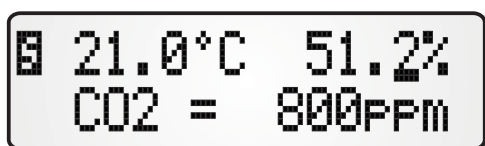
1. If necessary, move the cursor on the desired threshold with "▼" and "▲" keys.



2. Press **MENU**, the cursor passes in "underlined" mode.



3. Change the value with "▼" and "▲" keys.



4. Confirm by pressing **MENU** (or press **ESC** if you don't want to save the changes).



At the end, press **ESC** to return to the measuring mode. The instrument will automatically go back to the measuring mode if you don't press any key for 30 seconds.

The quick setting mode is not protected by an access code and thresholds can be changed only within predetermined limits, that shall be set with the following values:

**Tab. 4.G: Default settings for threshold limits in HD46 models (simplified mode)**

Temperature	Humidity	CO <sub>2</sub>
Threshold min. = 15.0 °C	Threshold min. = 20.0 %	Threshold min. = 600 ppm
Threshold max. = 25.0 °C	Threshold max. = 70.0 %	Threshold max. = 2000 ppm

To change intervals, hysteresis and relay activation modes, see section "CONFIGURATION".

In the simplified mode, the two threshold level mode is not available.

In models with keyboard, the simplified mode can be enabled by changing the *P#063* parameter (see section "Configuration by means of a keyboard").

*Note:* when an "M" appears on the top left side of the display (indicating access code enabled) and the MENU key is pressed, the threshold screen is not displayed, but you access the complete configuration mode (see section "Configuration by means of a keyboard").

### **Relay operation in "Complete mode"**

When the instrument is set in complete relay operation mode, each relay is associated with two configurable thresholds, named **A** and **B**. You can select either to make relays operate with both thresholds or with one of the two. The relay possible operating modes are as follows:

**1. Relay always disabled**

The contact is always open.

This mode is helpful in system maintenance and instrument configuration.

**2. Relay always enabled**

The contact is always closed.

This mode is helpful in system maintenance.

**3. Relay activates below threshold B**

The contact is closed if the measuring value falls below threshold **B** value. The contact is open if the measuring value is above threshold.

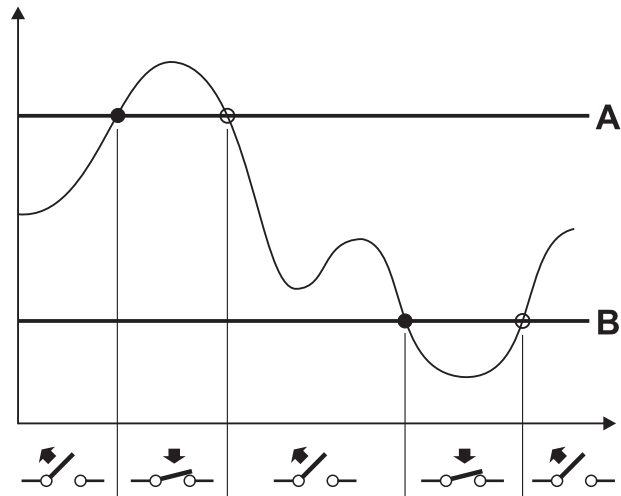
**4. Relay activates above threshold A**

The contact is closed if the measuring value rises above threshold **A** value. The contact is open if the measuring value is below threshold.

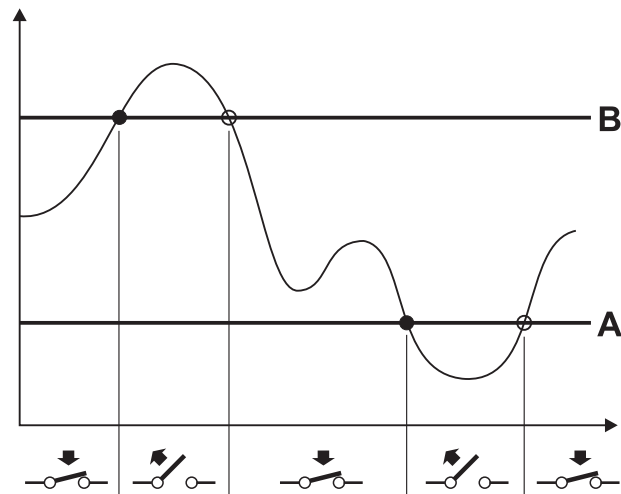
**5. Relay activates above threshold A and below threshold B.**

Relay action is different depending if threshold **A** value is greater or lower than threshold **B** value.

If threshold **A** value is greater than threshold **B** value, the contact is closed if the measuring value rises above threshold **A** value or falls below threshold **B** value. The contact is open if the measuring value is within the two threshold values.

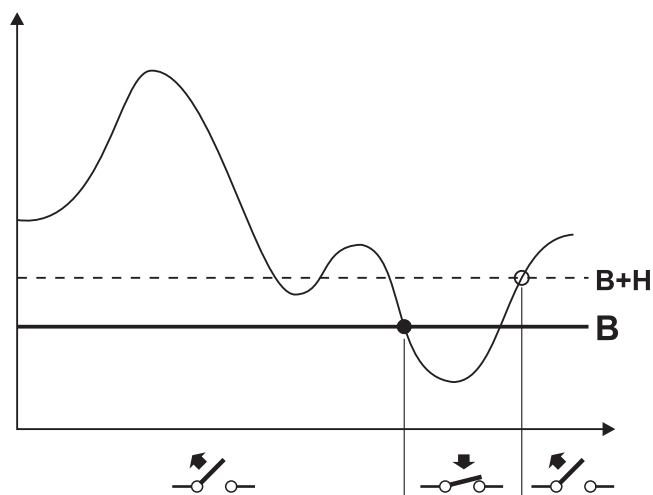


If threshold **A** value is lower than threshold **B** value, the contact is open if the measuring value rises above threshold **B** value or falls below threshold **A** value. The contact is closed if the measuring value is within the two threshold values.



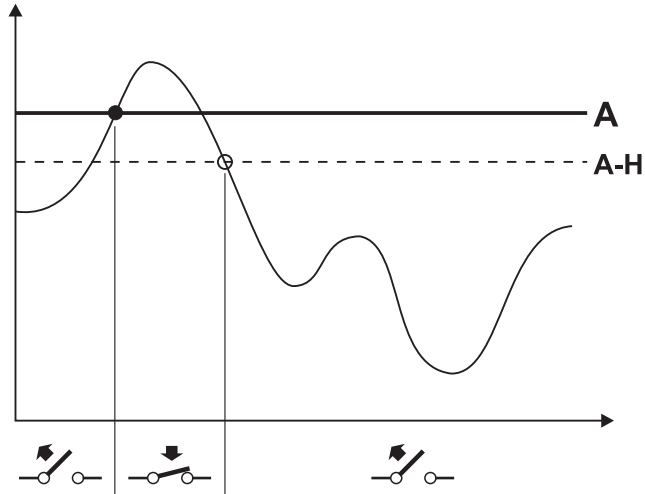
### 6. Relay activates below threshold **B** with hysteresis

The contact closes if the measured value falls below threshold **B**. Contact opens if the measured value rises above the threshold value plus the hysteresis (**B+H**).



### 7. Relay activates above threshold **A** with hysteresis

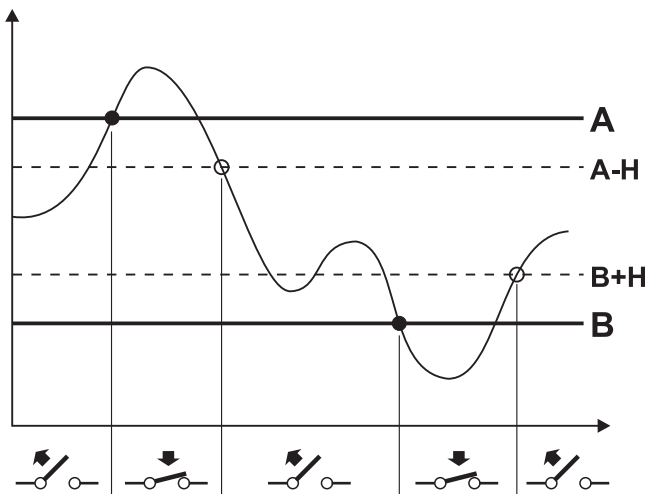
The contact closes when the measuring value rises above threshold **A** value. The contact opens if the measuring value falls below the threshold minus the hysteresis (**A-H**).



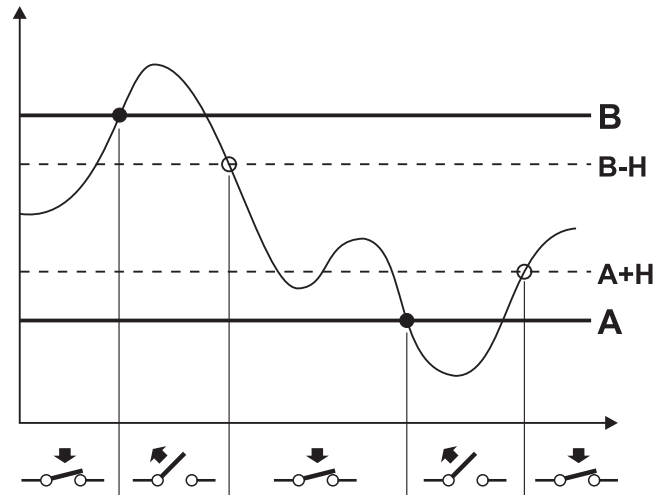
### 8. Relay activates above threshold **A** and below threshold **B** with hysteresis

Relay action is different depending if threshold **A** value is greater or lower than threshold **B** value.

If threshold **A** value is greater than threshold **B** value, the contact is closed if the measuring value rises above threshold **A** value or falls below threshold **B** value. The contact is open if the measuring value is within the interval ranging between threshold **B** plus the hysteresis (**B+H**) and threshold **A** minus the hysteresis (**A-H**).



If threshold **A** value is lower than threshold **B**, the contact opens if the measuring value rises above threshold **B** value or falls below threshold **A** value. The contact closes if the measuring value is within the interval ranging between threshold **A** plus the hysteresis (**A+H**) and threshold **B** minus the hysteresis (**B-H**).



In this mode, the hysteresis amplitude should be lower than the difference between the two intervention thresholds.

Hysteresis prevents the relay oscillation between the two states, when the measuring value is very close to the set threshold value. The hysteresis value can be zeroed or the operation mode without hysteresis can be used; however, it is recommended to keep hysteresis active in order to avoid malfunctions near the relay intervention point.

In **HD45**, the factory-set functionality is "Relay active above threshold **A** with hysteresis".

In **HD46**, the factory-set functionality is "Relay active above threshold **A** with hysteresis" for CO<sub>2</sub> and humidity, and "Relay active below threshold **B** with hysteresis" for temperature.

Further to the above mentioned modes, the relay contact can also be made to close when an error occurs relating to the measured quantity, for example in case of sensor fault or of a value measured over the set range.

Thus, the relay can be used:

- only to check the measured quantity;
- only to signal an error condition;
- either to control the measured quantity and to indicate an error condition.

In the last case, as it is not possible to make out if the relay contact is closed to indicate an error or because the instrument is adjusting the measured quantity, it is necessary to verify if the instrument is indicating a fault on the display or through a LED (see section 4.5 "Indicating a fault").

Each relay operating mode is set via connection to a PC, with the help of **DeltaLog14** program or through the protocol specified in section "COMMUNICATION PROTOCOL".

Settings can be performed also via a RS485 connection (see section "RS485 CONNECTION") or by means of the front keyboard (see section "Configuration through a keyboard", if available).





### 4.3 LED indicators in HD45 BVR and HD45 BAR models

**HD45 BVR** and **HD45 BAR** models are supplied with four LEDs which show the air quality level.

The passage from a level to the other is established based on the values of three thresholds, preset to the following values.

Lower threshold = 600 ppm  
Medium threshold = 800 ppm  
Upper threshold = 1400 ppm.

The level indication is obtained according to the following procedure:

<i>Optimal:</i>	It is on the green LED		$\text{CO}_2 < \text{Lower threshold (600 ppm)}$
<i>Satisfying:</i>	it is on the green LED		$\text{CO}_2 > \text{Lower threshold (600 ppm)}$ $\text{CO}_2 < \text{Medium threshold (800 ppm)}$
<i>Mediocre:</i>	It is on the yellow LED		$\text{CO}_2 > \text{Medium threshold (800 ppm)}$ $\text{CO}_2 < \text{Upper threshold (1400 ppm)}$
<i>Poor:</i>	It is on the red LED		$\text{CO}_2 > \text{Upper threshold (1400 ppm)}$

LEDs turn off when the measuring value falls below the threshold minus the hysteresis, which is common to the three thresholds and is factory preset to 20 ppm.

Threshold values and hysteresis can be configured. For the setting procedure, see section "CONFIGURATION".

LED indicators operate independently from relay operation. Indicator thresholds and hysteresis are different parameters than relay thresholds and hysteresis. So, relay can be activated at different values than LED thresholds.

### 4.4 Logging

Instruments are in continuous logging mode from the moment they are powered. The logging interval is preset to 5 minutes.

The instrument can store up to 2304 samples. Each sample consists of all the values measured by the instrument. Samples do not include date and time of data acquisition.

Memory is managed in a circular way, so that, when memory is full, the most recent samples overwrite the older ones.

If power supply is interrupted and then restored, logging is restarted in a new session, allowing in this way identification of stored data in the current run session.

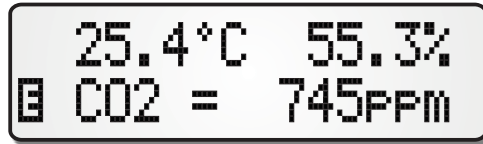
Stored values can be downloaded to a PC with the help of the application program **DeltaLog14** or through the protocol indicated in the section "COMMUNICATION PROTOCOL".

The logging interval can be set to 1 minute or 30 seconds. For the interval change mode, see section "CONFIGURATION".

## 4.5 Indicating a fault

All models have an error signal mode.

Models with display indicate an error condition by displaying an "E" on a black background, alternated to the error code, on bottom left of screen.



**Fig. 4.D: Error condition signal**

Several errors are indicated in a sequence, alternated by the symbol "E":

**Tab. 4.H: Error codes**

ERROR CODE	DESCRIPTION
1	Humidity module not present or faulty
2	Error in humidity module calibration data
3	Humidity module calibration data not present
4	Error in configuration and/or calibration data
5	Program memory altered
6	Error in temperature calibration
7	Temperature measure out of range
8	Humidity measure out of range
9	CO <sub>2</sub> measure out of range

In models without display, when an error occurs, the "POWER" LED flashes a number of times equal to the error number, spaced by a sequence of quick flashes. Several errors are indicated in a sequence, spaced by quick flashes.

In **HD46...R** models, when an error occurs in measuring a quantity, the respective LED flashes.

In **HD45...V...**, **HD45...A...**, **HD46...V** and **HD46...A** models, the analog output is set to 11Vdc or 22mA if there is a measuring error (for example, in case of sensor fault).

## 5. CONFIGURATION

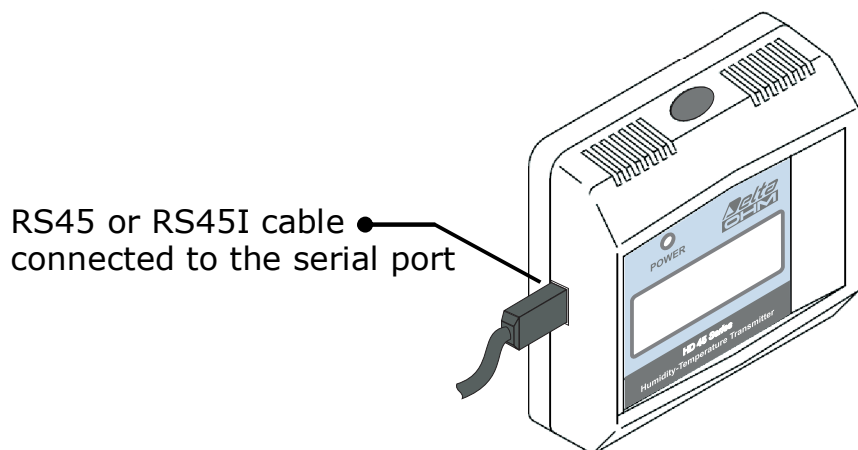
All transmitters have a mini-USB type, serial connector, located on the instrument side (Fig. 5.A), through which the instrument can be connected to a PC for configuration parameters setup.

Connection is made by means of the special **RS45** (not isolated) or **RS45I** (isolated) cable, which has a built-in USB adaptor and is supplied with a mini-USB connector for the instrument plus a USB connector for the PC. For a correct connection, USB drivers included in the **DeltaLog14** software package (the software can be downloaded from the Delta OHM website) must be installed in your PC.

*Attention:* the serial connection will not work if the instrument is directly connected to a PC by means of a standard mini-USB/USB adaptor cable. For a serial connection, you will need the special **RS45** or **RS45I** cable.

With the **RS45** cable, the instrument is powered directly by the USB port of a PC (at least a 500 mA USB port is required), allowing in this way on-site instrument configuration by means of a portable PC.

The PC can be connected even if the instrument has been already installed and power supplied; the instrument is designed to avoid interferences between the two power supplies. With the **RS45I** cable, the instrument is not powered by the PC USB port.



**Fig. 5.A: Serial connection (mini-USB connector)**

The instrument parameters setup can be easily performed by means of the application program for PC **DeltaLog14**. In such case, please refer to the software manual for parameters setting.

The instrument can also be configured through the serial connection without the help of the application program **DeltaLog14**, by using the serial protocol indicated in section "COMMUNICATION PROTOCOL".

In **HD45...S...** and **HD46...S...** models, the instrument setup can be performed through a RS485 connection. See section "RS485 COMMUNICATION".

**HD46...DT...** models can be configured by means of the front keyboard, with no need of PC connection. For keyboard setting, please refer to section "Configuration through keyboard".

The instrument continues to measure normally also when it is in configuration mode; any analog outputs or relays are regularly updated for the measured values. Changes made to parameters have an immediate effect (from measure cycle next to parameter confirmation).

## 5.1 Authorization levels

For the instrument configuration parameters setup, various authorization levels have been planned, so as to prevent any changes to the instrument functions by non-authorized personnel. Each parameter is associated with an authorization level, which can differ from that of other parameters.

The following authorization levels have been provided:

Level **0**: **operator** level.

Level **1**: **administrator** level.

Level **0** parameters are not protected and can be displayed and changed by every operator.

Level **1** parameters are protected by an access code. To view and change the parameters, the user needs an access code.

The default level is **1**.

For level **1** parameters, the default value for the access code is **000000**, that can be changed by the user via serial connection, if necessary, with the help of **DeltaLog14**

**If the access code is changed, make sure to keep the new code in a safe place. There are no commands for the "reset" of the access code. The loss of the code precludes the possibility to change the configuration parameters set to authorisation level 1.**

In case of loss of the access code, the user shall address the technical service **giving them a number supplied by the instrument**, through which it will be possible to trace the code in the transmitter memory.

The number to be communicated is obtained via serial connection, by means of **DeltaLog14** application program or through the command PW of the communication protocol (see section "COMMUNICATION PROTOCOL").

In models with keyboard, the number to be communicated can be obtained following the steps below:

1. Press **MENU** for at least 2 seconds, until the message "*Press MENU to edit parameters*" appears on the display.
2. Using "**▼**" and "**▲**" keys, enter any number as first digit of the access code and confirm with **MENU**.
3. Press **MENU** five times without entering any digits.
4. Take note of the number that will appear on the display and call the technical service.



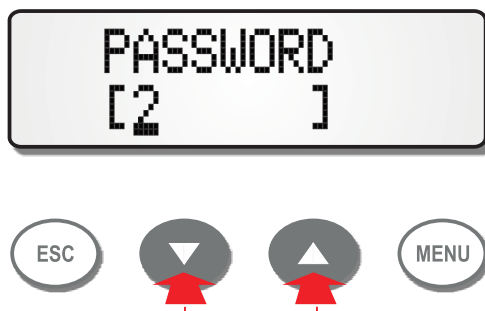
## 5.2 Configuration through keyboard (HD46...DT... only)

In models with keyboard, press and hold the **MENU** key for at least 2 seconds to access the configuration mode, until the message "Press MENU to edit parameters" appears on the display.



To access as operator (level "0"), simply press the **MENU** key. The only viewable parameters will be those in level "0".

To access as administrator (level "1"), it is necessary to enter the 6-digit access code. In such case, don't press **MENU** when the message "Press MENU to edit parameters" appears, but press "▼" or "▲" to set the first digit of the code.



Confirm the entered digit by pressing **MENU**, the cursor will move on the second digit. Enter the other 5 code digits in the same way.

*Note:* the entered digit remains "in evidence" for one second, then it is replaced by an asterisk, even if it hasn't yet been confirmed. Even if it is no more visible, the digit has been set and can be confirmed by pressing **MENU**.

The default value for the access code is **000000**.

For each parameter, the following will be displayed: sequence number, parameter value and authorization level.



The complete list of the available parameters is indicated in Tab. 5.A (page 29).

Select the desired parameter with "▼" and "▲" keys.



To quickly scroll through the list, press and hold one of the two arrow keys.

The parameter value is preceded by the indication (d) if expressed in decimals, or by (h) if expressed in hexadecimal.

Press the **MENU** key to access Edit mode, a full flashing cursor will appear in correspondence with the parameter value.



At this point, you can select if to edit the parameter value or the authorization level.

### **Changing the parameter value**

When the full cursor flashes on the parameter value, press again the **MENU** key. The cursor moves to the "underlined" mode.



Use the "▼" and "▲" keys to increment or decrement the value.



Confirm by pressing the **MENU** key, the cursor disappears.



At this point, you can scroll again through the parameter list with the arrow keys.

### **Changing the protection level**

When the full cursor flashes on the parameter value, press again the "▼" or "▲" keys to move the full flashing cursor on the level value.



Press the **MENU** key, the cursor will move to the "underlined" mode.



Use the "▼" and "▲" keys to increment or decrement the value.



Confirm by pressing **MENU**, the cursor disappears.



At this point, you can scroll again through the parameter list with the arrow keys.

The authorization level can be changed only if you are in configuration mode as administrator, that is through an access code. If a parameter is set to level **0**, and you accessed the configuration mode as an operator, the level cannot be increased, but only changed.

### **Escaping from configuration mode**

To exit configuration mode, press the **ESC** key at any time.

If the cursor is not on the display, by pressing **ESC** the instrument returns directly to the measuring mode. If on the contrary the cursor is displayed, the instrument exits edit mode (the cursor disappears) but remains in configuration mode; press again **ESC** to exit.

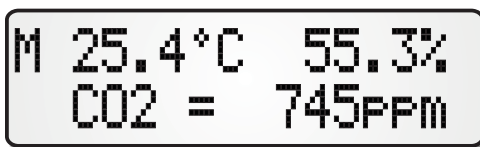


Any changes which have not been confirmed, will be deleted.

The instrument leaves automatically the configuration mode and returns to the measuring mode if keys are not pressed for 30 seconds.

If the access code has been entered, it remains active for 5 minutes after returning to the measuring mode. If **MENU** is pressed for less than 2 seconds within the 5-minute

interval, the instrument directly accesses configuration mode without asking the access code. The access code condition is shown by an "M" displayed on left top of the screen.



To disable the access code before the 5-minute interval has elapsed, press and hold the **MENU** key for at least 2 seconds, until the message "Press MENU to edit parameters" is displayed, then access configuration mode as an operator by pressing **MENU** and exit by pressing **ESC**.

### Configuration parameters list

The table below shows the complete list of the instrument parameters, along with settable values and default values ("DEFAULT" column).

**Tab. 5.A: Configuration parameters**

P#	DESCRIPTION	VALUE	DEFAULT	NOTE
000	User code	Alphanumeric code Max 34 digits.		(1)
001	User calibration date			(2)
002	Number of samples to be averaged for measure printing on serial port	MIN: <b>1</b> MAX: <b>20</b>	1	
003	CO <sub>2</sub> calibration point (ppm)	MIN: <b>200</b> MAX: <b>600</b>	400	
004	Atmospheric pressure (hPa)	MIN: <b>0</b> MAX: <b>3000</b>	1013	
005	Logging interval	<b>0</b> : 30 seconds <b>1</b> : 1 minute <b>2</b> : 5 minutes	2	
006	Temperature measuring unit	<b>0</b> : °C <b>1</b> : °F	0	
007	Humidity measuring type	<b>0</b> : RH% <b>1</b> : Dewpoint $T_d$ in °C <b>2</b> : $T_{ambient} - T_d$ in °C	0	
008	CO <sub>2</sub> output configuration	<b>00</b> : standard (0...10V or 4...20mA) <b>01</b> : remove offset (0...10V or 0...20mA) <b>02</b> : add offset (2...10V or 4...20mA) <b>04</b> : invert standard (10...0V or 20...4mA) <b>05</b> : invert and remove offset (10...0V or 20...0mA) <b>06</b> : invert and add offset (10...2V or 20...4mA)	00	
009	Temperature output configuration	As P#008	00	
010	Humidity output configuration	As P#008	00	

(1) Can be changed only through serial connection.

(2) Automatically updated by PC application software following to calibration.

### Temperature analog output (°C)

P#	DESCRIPTION	VALUE	DEFAULT	NOTE
011	Minimum °C temperature that can be associated to minimum scale analog output (x10)	MIN: <b>-300</b> (-30.0°C) MAX: P#012	-300	(3)
012	°C temperature at minimum scale analog output (x10)	MIN: P#011 MAX: P#013 – P#015	-200	(3)
013	°C temperature at 10V or 20mA analog output (x10)	MIN: P#012 + P#015 MAX: P#014	800	(3)
014	Maximum °C temperature that can be associated to 10V or 20mA analog output (x10)	MIN: P#013 MAX: <b>850</b> (85.0°C)	850	(3)
015	Minimum °C temperature range for analog output (x10)	MIN: <b>100</b> (10.0°C)	200	(3)

(3) The displayed value is the quantity value multiplied by 10 (decimal point not shown).

### Temperature (°F) analog output

P#	DESCRIPTION	VALUE	DEFAULT	NOTE
016	Minimum °F temperature that can be associated to minimum scale analog output (x10)	MIN: <b>-220</b> (-22.0°F) MAX: P#017	-220	(3)
017	°F temperature at minimum scale analog output (x10)	MIN: P#016 MAX: P#018 – P#020	-40	(3)
018	°F temperature at 10V or 20mA analog output (x10)	MIN: P#017 + P#020 MAX: P#019	1760	(3)
019	Maximum °F temperature that can be associated to 10V or 20mA analog output (x10)	MIN: P#018 MAX: <b>1850</b> (185.0°F)	1850	(3)
020	Minimum °C temperature range for analog output (x10)	MIN: <b>180</b> (18.0°F)	360	(3)

(3) The displayed value is the quantity value multiplied by 10 (decimal point not shown).

### Humidity analog output (RH%)

P#	DESCRIPTION	VALUE	DEFAULT	NOTE
021	Minimum % relative humidity that can be associated to minimum scale analog output (x10)	MIN: <b>0</b> (0.0%) MAX: P#022	0	(3)
022	% relative humidity at minimum scale analog output (x10)	MIN: P#021 MAX: P#023 – P#025	0	(3)
023	% relative humidity at 10V or 20mA analog output (x10)	MIN: P#022 + P#025 MAX: P#024	1000	(3)
024	Maximum % relative humidity that can be associated to 10V or 20mA analog output (x10)	MIN: P#023 MAX: <b>1000</b> (100.0%)	1000	(3)
025	Minimum % relative humidity range for analog output (x10)	MIN: <b>100</b> (10.0%)	200	(3)

(3) The displayed value is the quantity value multiplied by 10 (decimal point not shown).

### Humidity analog output ( $T_d$ °C)

P#	DESCRIPTION	VALUE	DEFAULT	NOTE
026	Minimum °C dewpoint that can be associated to minimum scale analog output (x10)	MIN: <b>-400</b> (-40.0°C) MAX: P#027	-400	(3)
027	°C dewpoint at minimum scale analog output (x10)	MIN: P#026 MAX: P#028 – P#030	-300	(3)
028	°C dewpoint at 10V or 20mA analog output (x10)	MIN: P#027 + P#030 MAX: P#029	800	(3)
029	Maximum °C dewpoint that can be associated to 10V or 20mA analog output (x10)	MIN: P#028 MAX: <b>850</b> (85.0°C)	850	(3)
030	Minimum °C dewpoint range for analog output (x10)	MIN: <b>50</b> (5.0°C)	200	(3)

(3) The displayed value is the quantity value multiplied by 10 (decimal point not shown)

### Humidity analog output ( $T_{\text{ambient}} - T_d$ °C)

P#	DESCRIPTION	VALUE	DEFAULT	NOTE
031	Minimum °C $T_a - T_d$ that can be associated to minimum scale analog output (x10)	MIN: <b>0</b> MAX: P#032	0	(3)
032	°C $T_a - T_d$ at minimum scale analog output (x10)	MIN: P#031 MAX: P#033 – P#035	0	(3)
033	°C $T_a - T_d$ at 10V or 20mA analog output (x10)	MIN: P#032 + P#035 MAX: P#034	400	(3)
034	Maximum °C $T_a - T_d$ that can be associated to 10V or 20mA analog output (x10)	MIN: P#033 MAX: <b>450</b> (45.0°C)	450	(3)
035	Minimum °C $T_a - T_d$ range for analog output (x10)	MIN: <b>50</b> (5.0°C)	100	(3)

(3) The displayed value is the quantity value multiplied by 10 (decimal point not shown).

### CO<sub>2</sub> analog output (ppm)

P#	DESCRIPTION	VALUE	DEFAULT	NOTE
036	Minimum CO <sub>2</sub> ppm value that can be associated to minimum scale analog output	MIN: <b>0</b> MAX: P#037	0	
037	CO <sub>2</sub> ppm value at minimum scale analog output	MIN: P#036 MAX: P#038 – P#040	0	
038	CO <sub>2</sub> ppm value at 10V or 20mA analog output	MIN: P#037 + P#040 MAX: P#039	5000	
039	Maximum CO <sub>2</sub> ppm value that can be associated to 10V or 20mA analog output	MIN: P#038 MAX: <b>5200</b>	5200	
040	Minimum CO <sub>2</sub> ppm value for analog output	MIN: <b>1000</b>	1000	

## Relay outputs

P#	DESCRIPTION	VALUE	DEFAULT	NOTE
<b>041</b>	<p>Relay operating mode in HD45 models and CO<sub>2</sub> relay operating mode in HD46 models with simplified mode disabled.</p> <p>In HD45 models, this is the mode with rotary selector in position 0. In HD46 models, this is the mode when the threshold simplified setting is disabled.</p>	<p><b>00:</b> <i>always disabled</i></p> <p><b>01:</b> <i>active below threshold B</i></p> <p><b>02:</b> <i>active over threshold A</i></p> <p><b>03:</b> <i>active over threshold A and below threshold B</i></p> <p><b>05:</b> <i>active below threshold B with hysteresis</i></p> <p><b>06:</b> <i>active over threshold A with hysteresis</i></p> <p><b>07:</b> <i>active over threshold A and below threshold B with hysteresis</i></p> <p><b>08:</b> <i>active only if in error</i></p> <p><b>09:</b> <i>active below threshold B and if in error</i></p> <p><b>0A:</b> <i>active over threshold A</i></p> <p><b>0B:</b> <i>active over threshold A, below threshold B and if in error</i></p> <p><b>0D:</b> <i>active below threshold B with hyster. and in error</i></p> <p><b>0E:</b> <i>active over threshold A with hyster. and in error</i></p> <p><b>0F:</b> <i>active over threshold A and below threshold B with hyster. and in error</i></p> <p><b>FF:</b> <i>always enabled</i></p>	06	(6)
<b>042</b>	Temperature relay operating mode in HD46 models with simplified mode disabled.	As P#041	05	
<b>043</b>	Humidity relay operating mode in HD46 models with simplified mode disabled.	As P#041	06	
<b>044</b>	<p>Threshold <b>B</b> relay in HD45 and CO<sub>2</sub> relay in HD46 (relay activated below threshold)</p> <p>Thres. is in ppm if associated with CO<sub>2</sub>. Threshold is x10 if associated with humidity or temperature in HD45</p>	<i>Over the whole range</i>	1000	(3),(4) (6)
<b>045</b>	Threshold <b>B</b> (x10) temp. relay in HD46 (relay activated below thres.)	<i>Over the whole range</i>	200	(3),(4)
<b>046</b>	Threshold <b>B</b> (x10) humidity relay in HD46 (relay activated below thres.)	<i>Over the whole range</i>	500	(3),(4)
<b>047</b>	<p>Threshold <b>A</b> relay in HD45 and CO<sub>2</sub> relay in HD46 (relay activated over threshold)</p> <p>Thres. is in ppm if associated with CO<sub>2</sub>. Threshold is x10 if associated with humidity or temperature in HD45.</p>	<i>Over the whole range</i>	1000	(3),(4) (6)
<b>048</b>	Threshold <b>A</b> (x10) temp. relay in HD46 (relay activated over thres.)	<i>Over the whole range</i>	200	(3),(4)
<b>049</b>	Threshold <b>A</b> (x10) humidity relay in HD46 (relay activated over thres.)	<i>Over the whole range</i>	500	(3),(4)



## Relay outputs

P#	DESCRIPTION	VALUE	DEFAULT	NOTE
050	Hysteresis relay in HD45 and CO <sub>2</sub> relay in HD46 In HD45... models it is the hysteresis when the rotary selector is in position 0 Value is in ppm if associated with CO <sub>2</sub> . Value is x10 if associated with humidity or temperature in HD45.	<i>Over the whole range</i>	100 ( HD45 B, HD46) 50 ( HD45 17, HD45 7B)	(3),(4)
051	Hysteresis (x10) temperature relay in HD46	<i>Over the whole range</i>	50	(3),(4)
052	Hysteresis (x10) humidity relay in HD46	<i>Over the whole range</i>	50	(3),(4)
053	Relay assignment in HD45...R	<b>0:</b> <i>not assigned</i> <b>1:</b> <i>CO<sub>2</sub></i> <b>2:</b> <i>Temperature</i> <b>3:</b> <i>Humidity</i>	1 (HD45 B) 2 (HD45 17, HD45 7B)	(5)
054	Lower threshold in ppm for LED indicators in HD45 BVR and HD45 BAR model	MIN: <b>400</b> MAX: <b>800</b>	600	(5)
055	Medium threshold in ppm for LED indicators in HD45 BVR and HD45 BAR model	MIN: <b>500</b> MAX: <b>2000</b>	800	(5)
056	Upper threshold in ppm for LED indicators in HD45 BVR and HD45 BAR model	MIN: <b>1000</b> MAX: <b>4000</b>	1400	(5)
057	Threshold hysteresis in ppm for LED indicators in HD45 BVR and HD45 BAR model	MIN: <b>0</b> MAX: <b>100</b>	20	(5)
062	Relay operating mode in HD45 models when rotary selector is in position other than 0.	<b>0:</b> <i>Active below threshold</i> <b>1:</b> <i>Active over threshold</i>	1	(5)
063	Relay simplified mode activation in HD46 models	<b>0:</b> <i>Disable simplified mode</i> <b>1:</b> <i>Enable simplified mode</i>	0	
064	CO <sub>2</sub> relay operating mode in HD46 with simplified mode enabled.	<b>0:</b> <i>Active below threshold</i> <b>1:</b> <i>Active over threshold</i>	1	
065	Temperature relay operating mode in HD46 with simplified mode enabled.	<b>0:</b> <i>Active below threshold</i> <b>1:</b> <i>Active over threshold</i>	1	
066	Humidity relay operating mode in HD46 with simplified mode enabled.	<b>0:</b> <i>Active below threshold</i> <b>1:</b> <i>Active over threshold</i>	1	
082	Rotary selector threshold in position 1 when the relay is associated with humidity or temperature measure (x10)	<i>Over the whole range</i>	180	(4),(5)
083	Rotary selector increment for positions 2...9 when the relay is associated with humidity or temperature measure (x10)	<i>Over the whole range</i>	50	(4),(5)
084	Relay hysteresis when rotary selector is in position other than 0 (x10 if related to humidity or temperature)	<i>Over the whole range</i>	100 (HD45 B) 50 ( HD45 17, HD45 7B)	(4),(5)

### Relay outputs

P#	DESCRIPTION	VALUE	DEFAULT	NOTE
085	Ppm threshold for CO <sub>2</sub> relay in HD46 models with simplified mode enabled.	<i>Over the whole range</i>	800	(6)
086	Temperature relay threshold (X10) in HD46 models with simplified mode enabled.	<i>Over the whole range</i>	210	(3),(4) (6)
087	Humidity relay threshold (X10) in HD46 models with simplified mode enabled.	<i>Over the whole range</i>	500	(3),(4) (6)
088	Minimum possible threshold in ppm for CO <sub>2</sub> relay in HD46 models with simplified mode enabled.	<i>Over the whole range</i>	600	
089	Minimum possible threshold (x10) for temperature relay in HD46 models with simplified mode enabled.	<i>Over the whole range</i>	150	(3),(4)
090	Minimum possible threshold (x10) for humidity relay in HD46 models with simplified mode enabled.	<i>Over the whole range</i>	200	(3),(4)
091	Minimum possible threshold in ppm for CO <sub>2</sub> relay in HD46 models with simplified mode enabled.	<i>Over the whole range</i>	2000	
092	Maximum possible threshold (x10) for temp. relay in HD46 models with simplified mode enabled.	<i>Over the whole range</i>	250	(3),(4)
093	Maximum possible threshold (x10) for humidity relay in HD46 models with simplified mode enabled.	<i>Over the whole range</i>	700	(3),(4)

(3) *The displayed value for temperature and humidity is the quantity value multiplied by 10 (decimal point not displayed).*

(4) *The parameter measuring unit is the same as the respective measured quantity, set with P#006 and P#007 parameters.*

(5) *This parameter is for HD45 models.*

(6) *In HD45 models with relay, if the hardware threshold selector is in position other than 0, the relay operates only with threshold set via hardware, A and B thresholds are not taken into account.*

*In HD46 models, if the simplified mode is enabled, relays operate with P#085, P#086 and P#087 thresholds. A and B thresholds are not taken into account.*

### MODBUS-RTU RS485 serial communication

P#	DESCRIPTION	VALUE	DEFAULT	NOTE
058	RS485 address	MIN: <b>1</b> MAX: <b>247</b>	1	
059	RS485 Baud rate	<b>0</b> : 9600 <b>1</b> : 19200	1	
060	RS485 transmission mode <i>Data Bits = 8</i> <i>Parity: N= none, E= even, O= odd</i> <i>Stop Bits: 1= 1bit, 2= 2 bit</i>	<b>0</b> : 8 N 1 <b>1</b> : 8 N 2 <b>2</b> : 8 E 1 <b>3</b> : 8 E 2 <b>4</b> : 8 O 1 <b>5</b> : 8 O 2	2	
061	Receiving mode after RS485 transmission	<b>0</b> : <i>do not respect protocol and starts receiving after transmission</i> <b>1</b> : <i>respects the protocol and waits for 3,5 char. after transmission</i>	1	

**Note: the parameters which are not included in Tab. 5.A are not used and cannot be entered.**

**The instrument always lists all parameters included in Tab 5.A, even if some of these are not scheduled for that particular model, for example because it has no analog outputs or no relays. Changing these parameters will produce no effects.**

### **Example of relay output configuration by means of the keyboard**

Suppose you wish to have the humidity relay activated when the measured value is:

- Greater than **60.0%**
- Lower than **35.0%**

applying a **3.0%** hysteresis.

You will have to select, accordingly, the mode "Relay active over threshold **A** and below threshold **B** with hysteresis". The operation mode with two thresholds requires the threshold quick setting mode to be disabled.

According to Tab 5.A, the humidity relay output configuration parameters are P#043, P#046, P#049, P#052 and P#063. Setup these parameters with the following values:

- Humidity relay operative mode *P#043* = **07**
- Threshold **B** for humidity relay *P#046* = **350** (the decimal point is not displayed)
- Threshold **A** for humidity relay *P#049* = **600** (the decimal point is not displayed)
- Hysteresis for humidity relay *P#052* = **30** (the decimal point is not displayed)
- Simplified mode activation *P#063* = **0** (default setting)

The complete procedure is as follows:

1. Press **MENU** to access configuration mode.
2. Enter the access code if parameters have been assigned authorization level 1 (default setting), or press **MENU** if the parameters level is 0.
3. Select parameter P#063 with the "▼" and "▲" keys, check that value is 0 (default setting).
4. If P#063 value is other than 0, press **MENU** twice to access the Edit mode and change the value to 0 with the "▼" and "▲" keys, then press **MENU** to confirm.
5. Select parameter P#043 with the "▼" key, then press **MENU** twice to access Edit mode.
6. Change P#043 value to 07 with the "▼" and "▲" keys, then press **MENU** to confirm.
7. Select P#046 parameter with the "▲" key, then press **MENU** twice to access Edit mode.
8. Change P#046 value to 350 with the "▼" and "▲" keys, then press **MENU** to confirm.

9. Select parameter P#049 with the "▲" key, then press **MENU** twice to access Edit mode.
10. Change P#049 value to 600 with the "▼" and "▲" keys, then press **MENU** to confirm.
11. Select P#052 parameter with the "▲" key, then press **MENU** twice to access Edit mode.
12. Change P#052 value to 30 with the "▼" and "▲" keys, then press **MENU** to confirm.
13. Press **ESC** to exit Configuration mode.

## 6. CALIBRATION

Instruments are factory-calibrated and normally don't require further interventions by the user.

**The relative humidity and temperature sensors user calibration is not foreseen.**

In HD46... models, relative humidity and temperature sensors, along with stored calibration data, are included in a module that can be easily replaced by a new one (**HDM46** code). **Modules are factory-calibrated and don't require user calibration. The replaced module can be sent to factory for recalibration.**

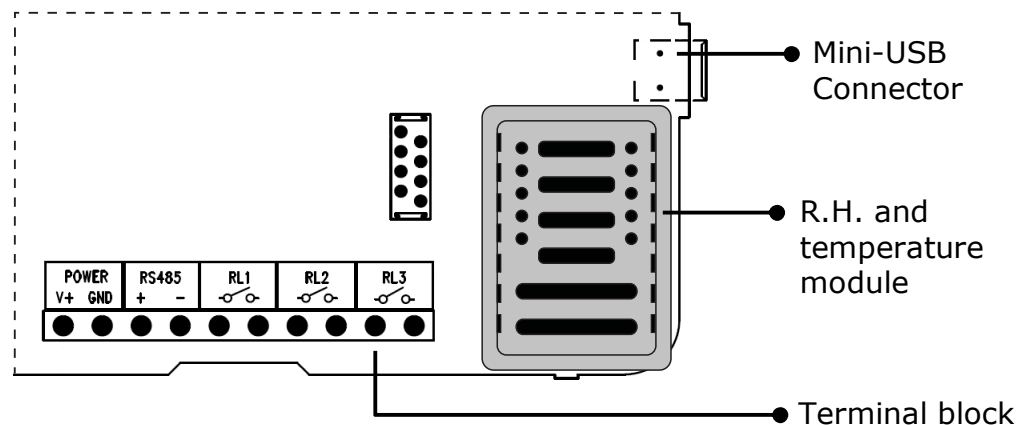
However, for CO<sub>2</sub> measuring modules, a new calibration can be performed for sensor offset correction.

### 6.1 Replacement of R.H. and temperature module (HD46...only)

To replace the relative humidity and temperature module, open the housing by pressing down the upper and lower tabs, then pull to remove the front panel (see Fig. 3.A in section "INSTALLATION AND CONNECTION").

Ensure power supply is not connected (PC not connected to mini-USB serial connector).

The module is located next to the terminal block, under the mini-USB serial connector (Fig. 6.A). To remove it, gently pull upwards.



**Fig. 6.A: R.H. and temperature module position in HD46... models**

Put the new module in place of the removed module, paying attention to position it in the correct direction (module contact pins must be positioned towards the mini-USB serial connector).

Once the procedure has been completed, reconnect the power supply and relocate the front panel ensuring to correctly position the upper and lower tabs.

## 6.2 CO<sub>2</sub> sensor calibration

CO<sub>2</sub> sensor calibration check can be performed every three/four years.

For a correct sensor calibration, it is crucial to know and respect the physical phenomena that represent measurement bases: for this reason, we recommend to thoroughly follow the information below and to perform new calibrations only if in possession of adequate technical knowledge.

CO<sub>2</sub> sensor can be calibrated in clean air. Each new calibration deletes the previous one.

To calibrate the sensor, proceed as follows:

1. Ensure the instrument is actually in clean air.
2. Power up the instrument by connecting the serial output to your PC USB port by means of the special **RS45** connection cable.
3. Wait for at least 15 minutes before proceeding.
4. Start **DeltaLog14** program and follow the guided sensor calibration procedure.

## 7. COMMUNICATION PROTOCOL

All models are supplied with a serial output with mini-USB connector, that allows you to upload commands and to download data through your PC using communication programs, such as – for example - Hyperterminal.

Connect the serial output located on the instrument side to a USB port of your PC via the special **RS45** or **RS45I** connection cable, which is supplied with a built-in USB adaptor and mini-USB connector to the instrument end, and a USB connector to the PC end. For a proper connection operation, it is necessary to install the drivers included in the **DeltaLog14** software package in your PC.

*Attention:* serial connection doesn't work if the instrument is directly connected to the PC via a standard mini-USB/USB adaptor cable.

After the connection, the instrument appears connected to a COM-type port.

Setup serial transmission parameters as follows:

Baud rate: 115200, Parity: None, Data bits: 8, Stop bits: 2

Please find below the list of configuration commands and data requests that can be sent through a PC, with the instrument connected via mini-USB output:

**Tab. 7.A: Communication protocol**

Command	Response	Description
Cu0	&	Set the operating mode for circulating air
Cu1	&	Set the operating mode for still air
G0	HD...	Transmitter model
G1	Vnn.nn aaaa/mm/gg	Firmware version and date
G2	aaaa/mm/gg hh.mm.ss	Calibration date and time
G3	nnnnnnnn	Instrument serial number
G4	nnnnnnnn	Relative humidity module serial number
G5	aaaa/mm/gg hh.mm.ss	Relative humidity module factory calibration date and time
GS		Download last logging session
GT		Download all logging sessions
Gu	0 (still air mode) or 1 (circulating air mode)	Read if the operating mode is for still or circulating air
PW	nnnnnn	Print number to retrieve access code
PWC nnnnnn nnnnnn	&	Set new "nnnnnn" access code
PWnnnnnn	USER ENABLED!	Upload access code and set authorization level "1"
PWX	LOCKED!	Set authorization level "0"
RLnnn	n	Print authorization level of parameter number "nnn"
RPnnn		Print value of parameter number "nnn"
S0	&	Disable measurement print
S1	&	Single measurement print
S2	&	Enable measurement continuous print
WLnnn x	&	Set authorization level of parameter number "nnn" to "x" value
WPnnn val	&	Set parameter number "nnn" to "val" value

For the available parameter list, refer to Tab. 5.A (page 29).

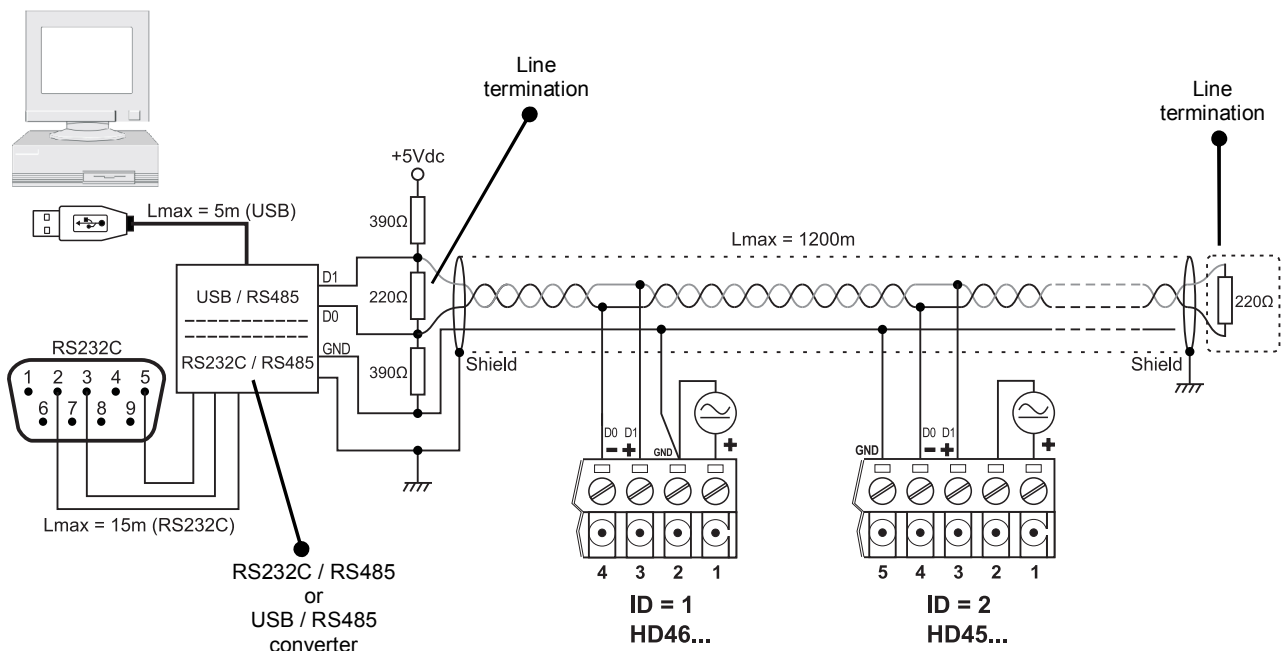
In measurement continuous printing, values are the average computed on a number of measurements equal to the number set for parameter P#002.

In models supplied also with a RS485 output, both serial outputs can be connected at the same time, but the transmitters support only one communication channel at a time. **If mini-USB and RS485 outputs are both connected, the mini-USB output prevails** and the instrument replies only to commands sent via USB connection and not to any commands sent on the RS485 line.

## 8. RS485 COMMUNICATION

**HD45...S...** and **HD46...S...** models are supplied with a RS485 serial output with **MODBUS-RTU** protocol. RS485 connection is located in the instrument internal terminal block (see section "CONNECTION AND INSTALLATION") and is suitable for fixed installations.

Thanks to RS485 output, several instruments can be connected to form a network, consisting of a minimum of 1 instrument to a maximum of **247**, connected in a sequence through a shielded cable with twisted pair for signals and a third wire for the common.



**Fig. 8.A: Connection to RS485 network for HD45 and HD46 models**

As shown in figure 8.A, resistors for impedance matching (line terminations) must be set at the two network ends. To polarize the line during non-transmission periods, resistors are connected between signal and power supply lines. Polarization resistors are located in a single point of the line, generally near the "Master" unit.

The cable shield must be connected to both line ends.

The cable should have the following features:



- Characteristic impedance: 120 ohm
- Capacity: less than 50pF/m
- Resistance: less than 100 ohm/km
- gauge: 0,22 mm<sup>2</sup> (AWG24) at least

If more than 32 devices have to be connected (that is, 31 instruments plus the Master unit), place a signal repeater between a group and the next one. The line termination must be connected at both ends of each segment.

The cable maximum length depends on baud rate and cable characteristics. Typically, the maximum length is 1200m.

The data line must be kept separated from any power lines in order to prevent interferences on the transmitted signal.

For connection to a PC, a RS232/RS485 or a USB/RS485 converter must be used.

Each transmitter placed on the network is univocally identified by an address, whose value ranges within 1 and 247. **Transmitters having the same address shall not be present in the network**, otherwise the "Master" unit will not be able to communicate with these devices due to signal conflicts in the line.

The default communication parameters are as follows:

- Baud rate: 19200
- Parity: Even
- Start bit: 1
- Data bits: 8
- Stop bit: 1

Transmitter address, baud rate, parity type and stop bits number are configurable parameters. See section "CONFIGURATION" for setup modes.

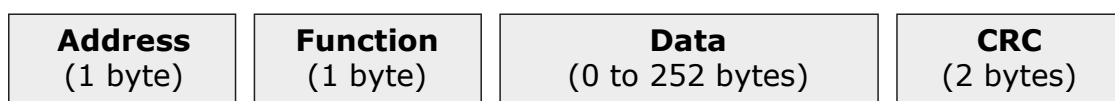
*Note:* communication via RS485 port is disabled if the instrument is connected to the PC through the mini-USB output.

The **DeltaLog14** software package includes utility files to make RS485 communication easier, see guide "Utility program for RS485 connection" included in the package. The following section describes the complete protocol.

## 8.1 MODBUS-RTU protocol

This protocol is "**Master-Slave**" type. The network includes only one "Master" device, typically a PC, the other units, the transmitters, are all "Slave" type. The "Master" unit can transmit commands and requests of data to the "Slave" devices on the network. A "Slave" device communicates only with the "Master" unit following a request from the latter. Direct communication between "Slave" devices is not allowed; additionally, "Slave" devices cannot transmit data on the line if not requested.

Commands transmitted by a PC to the instrument consist of four fields:

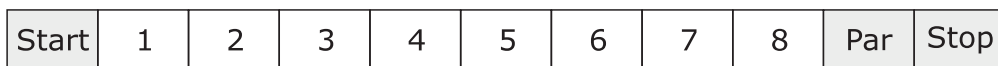


**Fig. 8.B: Data packet format in MODBUS-RTU protocol**

- *Address*: address of the transmitter for command transmission.  
*Length* = 1 byte
- *Function*: type of operation to be performed by the transmitter (for example, a parameter setup).  
*Length* = 1 byte
- *Data*: Data communicated to the transmitter (for example, a parameter value). The field can be empty in case of commands that don't involve data transfer from PC to instrument.  
*Length* = 0 to 252 bytes
- *CRC*: Data integrity control code (Cyclic Redundancy Code).  
*Length* = 2 bytes

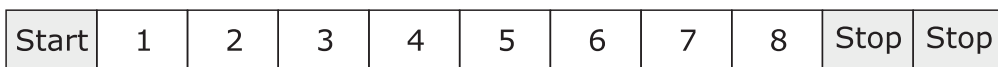
Each byte (8 bits) consists of two 4-bit hexadecimal characters.

Each byte is preceded by a start bit and followed by a parity bit plus a stop bit, for a total of 11 bits.



**Fig. 8.C: Byte format with parity bit in MODBUS-RTU protocol**

If parity is not used, the byte must be followed by two stop bits.

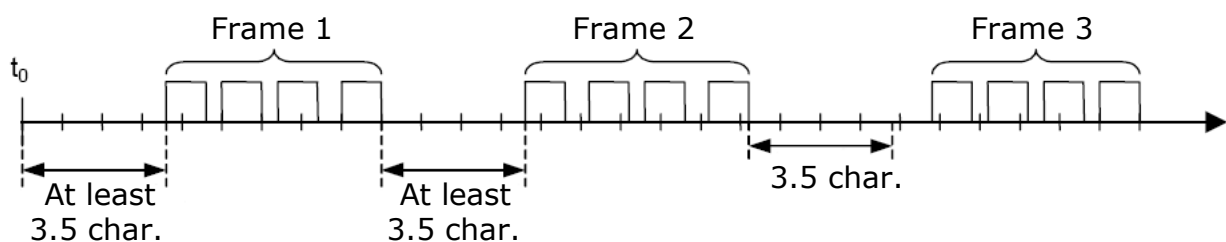


**Fig. 8.D: Byte format without parity bit in MODBUS-RTU protocol**

The byte is transmitted starting from the least significant bit (LSB).

All bytes in a command are transmitted in a series with no interruptions, starting from the address byte. The last byte to be transmitted is the most significant byte in the control code (CRC). If two consecutive bytes are separated by a pause greater than 1.5 characters, the command will be considered as invalid and will be rejected by the receiver.

There must be an interval of at least 3.5 characters between a command and the next one.



**Fig. 8.E: Frame sequence in MODBUS-RTU protocol**

After a pause in the line greater than 3.5 characters, the connected devices will consider the command transmission as terminated. The first received character after a pause will be considered as the start of a new command.

After processing the received command, the instrument will send a response to the PC, transmitting the requested data or only confirming the command execution if data transfer has not been requested. The response structure is identical to that of the message sent by the "Master" unit.

- *Address*: address of answering transmitter.  
*Length* = 1 byte
- *Function*: type of operation performed by transmitter.  
*Length* = 1 byte
- *Data*: Data communicated by transmitter to PC.  
*Length* = 0 to 252 byte
- *CRC*: CRC Control code.  
*Length* = 2 bytes

When value "0" is the address field, it means that the command has been sent to all transmitters in the network. In this case, instruments execute the command but don't send any response to PC, in order to prevent transmission conflicts between instruments. A command that is simultaneously sent to all instruments will be therefore a parameter setup command, but not a request of data.

In order to prevent transmission conflicts between instruments, the PC shall also have to wait for response from the questioned instrument before sending a new command.

If the instrument doesn't receive a correct command (time intervals between characters or control codes not respected), it will not reply to the PC. If the PC doesn't receive any response within a specified time interval (time-out), it will consider the command receipt by the receiver as not successful and will try again the transmission or will generate an error signal.

In appendix A, the CRC control code computing method is explained along with the use of the parity bit.

Functions that can be requested by the PC to the instrument, with their codes to be inserted in the command *Function* field, are described in the following table:

**Tab. 8.A: MODBUS functions**

Function code	Function
01h	Relay state reading
03h	Configuration parameters reading
04h	Measurements reading
05h	Permanent storage of changed parameters
06h	Single configuration parameter setup
07h	Error conditions reading
10h	Consecutive configuration parameter setup
2Bh	Instrument general information reading

**Relays state reading (function 01h)**

Function code 01h allows to read the relays activation state of the instrument.

The relays state can only be read, there are no commands available for relay state modification.

The register address for the first relay state and the number of consecutive relays to be read are indicated in the request data field.

Since registers are numbered starting from 1 in the protocol, and data are addressed starting from 0, a register address is equal to the register number decremented by 1.

The instrument replies with a byte, whose least significant bit (LSB) indicates the state of the first addressed relay, while the subsequent bits indicate the state of the other requested relays. The bits value is 1 if relay is active and 0 if relay is inactive. The bits following the last requested relay are set to 0 to complete the byte.

Consequently, the *Function* and *Data* fields of command and response will have the following format:

**Command**

	Value	Length	Description
<i>Function:</i>	01h	1 byte	Relay state reading command
<i>Data:</i>	0000h to FFFFh	2 bytes	First relay address
	0001h to 007Dh	2 bytes	Number of relays to be read ( <b>N</b> )

**Response**

	Value	Length	Description
<i>Function:</i>	01h	1 byte	Relay state reading command
<i>Data:</i>	01h	1 byte	Number of bytes with relay state
		1 byte	Relay state

The following table lists the available relays with their register number:

**Tab. 8.B: Relays state registers**

Register number	Relay	From FW Ver.	Notes
0004	Relay in HD45 models, whatever is the associated parameter CO <sub>2</sub> relay in HD46 models	1.08	
0005	Temperature relay in HD46 models	1.08	
0006	Humidity relay in HD46 models	1.08	

The state reading of the unavailable relays in that particular model is not allowed.

If the request involves the reading of at least one parameter which is not included in table 8.B, the instrument will answer with the following error message:

**Response**

	Value	Length	Description
<i>Function:</i>	81h	1 byte	Error in relay state reading
<i>Data:</i>	02h	1 byte	Operation involved a non-existent parameter (Tab. 8.F at page 59)

Example:

You want to read the current state of the three relays in a HD46 17BR model, and only the temperature relay is active:

You will have to include in the request:

- address (= number -1 ) of first relay register (0003 = 0003h)
- number of relays to be read (3 = 0003h).

Consequently, the command will have the following format:

**Command**

	<b>Value</b>	<b>Length</b>	<b>Description</b>
<i>Function:</i>	01h	1 byte	Relay state reading command
<i>Data:</i>	00h	2 bytes	First relay address (MSB)
	03h		First relay address (LSB)
	00h	2 bytes	Number of relays to be read (MSB)
	03h		Number of relays to be read (LSB)

The instrument will answer as follows:

**Response**

	<b>Value</b>	<b>Length</b>	<b>Description</b>
<i>Function:</i>	01h	1 byte	Relay state reading command
<i>Data:</i>	01h	1 byte	Number of bytes with relay state
	02h	1 byte	Relay state

The byte with the relay state is 02h = 0000 0010. The least significant bit corresponds to the CO<sub>2</sub> relay state (0 = disabled), the second bit corresponds to the temperature relay (1 = enabled), the third bit corresponds to the humidity relay (0 = disabled).

**Configuration parameters reading** (function **03h**)

Function code 03h allows to read a specified number of consecutive instrument parameters.

The configuration register address containing the first parameter to be read and the number of parameters to be read are indicated in the request data field.

Since, in the protocol, registers are numbered starting from 1, and data are addressed starting from 0, a register address is equal to the register number decremented by 1.

The instrument replies with the value of the requested parameters. Consequently, the *Function* and *Data* fields of command and Response will have the following format:

**Command**

	<b>Value</b>	<b>Length</b>	<b>Description</b>
<i>Function:</i>	03h	1 byte	Parameters reading command
<i>Data:</i>	0000h to FFFFh	2 bytes	First parameter address
	0001h to 007Dh	2 bytes	Number of parameters to be read ( <b>N</b> )

## Response

	Value	Length	Description
Function:	03h	1 byte	Parameters reading command
Data:	2 x <b>N</b>	1 byte	Number of bytes for the values
		2 x <b>N</b> bytes	Parameters values

A parameter value is stored in a 16-bit register and consequently requires always a 2-byte length. The most significant byte precedes the least significant one.

The following table lists the available parameters with their register number.

**Tab. 8.C: Configuration registers**

Register number	Parameter	Format	From FW Ver.	Notes
0001	P#000 User code - character 1 (ASCII)	8 bits (LSB)	1.00	(1),(2)
0002	P#000 User code - character 2 (ASCII)	8 bits (LSB)	1.00	(1),(2)
0003	P#000 User code - character 3 (ASCII)	8 bits (LSB)	1.00	(1),(2)
0004	P#000 User code - character 4 (ASCII)	8 bits (LSB)	1.00	(1),(2)
0005	P#000 User code - character 5 (ASCII)	8 bits (LSB)	1.00	(1),(2)
0006	P#000 User code - character 6 (ASCII)	8 bits (LSB)	1.00	(1),(2)
0007	P#000 User code - character 7 (ASCII)	8 bits (LSB)	1.00	(1),(2)
0008	P#000 User code - character 8 (ASCII)	8 bits (LSB)	1.00	(1),(2)
0009	P#000 User code - character 9 (ASCII)	8 bits (LSB)	1.00	(1),(2)
0010	P#000 User code - character 10 (ASCII)	8 bits (LSB)	1.00	(1),(2)
0011	P#000 User code - character 11 (ASCII)	8 bits (LSB)	1.00	(1),(2)
0012	P#000 User code - character 12 (ASCII)	8 bits (LSB)	1.00	(1),(2)
0013	P#000 User code - character 13 (ASCII)	8 bits (LSB)	1.00	(1),(2)
0014	P#000 User code - character 14 (ASCII)	8 bits (LSB)	1.00	(1),(2)
0015	P#000 User code - character 15 (ASCII)	8 bits (LSB)	1.00	(1),(2)
0016	P#000 User code - character 16 (ASCII)	8 bits (LSB)	1.00	(1),(2)
0017	P#000 User code - character 17 (ASCII)	8 bits (LSB)	1.00	(1),(2)
0018	P#000 User code - character 18 (ASCII)	8 bits (LSB)	1.00	(1),(2)
0019	P#000 User code - character 19 (ASCII)	8 bits (LSB)	1.00	(1),(2)
0020	P#000 User code - character 20 (ASCII)	8 bits (LSB)	1.00	(1),(2)
0021	P#000 User code - character 21 (ASCII)	8 bits (LSB)	1.00	(1),(2)
0022	P#000 User code - character 22 (ASCII)	8 bits (LSB)	1.00	(1),(2)
0023	P#000 User code - character 23 (ASCII)	8 bits (LSB)	1.00	(1),(2)
0024	P#000 User code - character 24 (ASCII)	8 bits (LSB)	1.00	(1),(2)
0025	P#000 User code - character 25 (ASCII)	8 bits (LSB)	1.00	(1),(2)
0026	P#000 User code - character 26 (ASCII)	8 bits (LSB)	1.00	(1),(2)
0027	P#000 User code - character 27 (ASCII)	8 bits (LSB)	1.00	(1),(2)
0028	P#000 User code - character 28 (ASCII)	8 bits (LSB)	1.00	(1),(2)
0029	P#000 User code - character 29 (ASCII)	8 bits (LSB)	1.00	(1),(2)
0030	P#000 User code - character 30 (ASCII)	8 bits (LSB)	1.00	(1),(2)
0031	P#000 User code - character 31 (ASCII)	8 bits (LSB)	1.00	(1),(2)
0032	P#000 User code - character 32 (ASCII)	8 bits (LSB)	1.00	(1),(2)
0033	P#000 User code - character 33 (ASCII)	8 bits (LSB)	1.00	(1),(2)
0034	P#000 User code - character 34 (ASCII)	8 bits (LSB)	1.00	(1),(2)
0035	P#001 User calibration - seconds	8 bits (LSB)	1.00	(1),(2)
0036	P#001 User calibration - minutes	8 bits (LSB)	1.00	(1),(2)
0037	P#001 User calibration - hours	8 bits (LSB)	1.00	(1),(2)
0038	P#001 User calibration - day	8 bits (LSB)	1.00	(1),(2)
0039	P#001 User calibration - month	8 bits (LSB)	1.00	(1),(2)
0040	P#001 User calibration - year	8 bits (LSB)	1.00	(1),(2)
0041	P#002 Number of samples to be averaged for measurement print on serial port	16 bits unsigned	1.00	

Register number	Parameter	Format	From FW Ver.	Notes
0042	P#003 Reference CO <sub>2</sub> [ppm]	Int 16 bits	1.00	
0043	P#004 Atmospheric pressure [hPa]	Int 16 bits	1.00	
0044	P#005 Logging interval	8 bits (LSB)	1.00	(2)
0045	P#006 Temperature measurement unit	8 bits (LSB)	1.00	(2)
0046	P#007 Humidity measurement unit	8 bits (LSB)	1.00	(2)
0047	P#008 CO <sub>2</sub> analog output configuration	8 bits (LSB)	1.00	(2)
0048	P#009 Temp. analog output configuration	8 bits (LSB)	1.00	(2)
0049	P#010 Humidity analog output configuration	8 bits (LSB)	1.00	(2)
0050	P#011 Min. temperature in °C at analog output minimum scale (x10)	Int 16 bits	1.00	
0051	P#012 Temperature in °C at analog output minimum scale (x10)	Int 16 bits	1.00	
0052	P#013 Temperature in °C at 10V or 20mA (x10)	Int 16 bits	1.00	
0053	P#014 Max. temperature (°C) at 10V or 20mA (x10)	Int 16 bits	1.00	
0054	P#015 Minimum temperature range in °C for the analog output (x10)	Int 16 bits	1.00	
0055	P#016 Min. temperature in °F at analog output minimum scale (x10)	Int 16 bits	1.00	
0056	P#017 Temperature in °F at analog output minimum scale (x10)	Int 16 bits	1.00	
0057	P#018 Temperature in °F at 10V or 20mA (x10)	Int 16 bits	1.00	
0058	P#019 Max. temperature in °F at 10V or 20mA (x10)	Int 16 bits	1.00	
0059	P#020 Minimum temperature range in °F for the analog output (x10)	Int 16 bits	1.00	
0060	P#021 Min. RH% at analog output minimum scale (x10)	Int 16 bits	1.00	
0061	P#022 RH% at analog output minimum scale (x10)	Int 16 bits	1.00	
0062	P#023 RH% at 10V or 20mA (x10)	Int 16 bits	1.00	
0063	P#024 Max. RH% at 10V or 20mA (x10)	Int 16 bits	1.00	
0064	P#025 RH% minimum range for the analog output (x10)	Int 16 bits	1.00	
0065	P#026 Min. Td (°C) at analog output minimum scale (x10)	Int 16 bits	1.00	
0066	P#027 Td (°C) at analog output minimum scale (x10)	Int 16 bits	1.00	
0067	P#028 Td (°C) at 10V or 20mA (x10)	Int 16 bits	1.00	
0068	P#029 Max. Td (°C) at 10V or 20mA (x10)	Int 16 bits	1.00	
0069	P#030 Td (°C) minimum range for the analog output (x10)	Int 16 bits	1.00	
0070	P#031 Min. (Ta-Td) in °C at analog output minimum scale (x10)	Int 16 bits	1.00	
0071	P#032 (Ta-Td) in °C at analog output minimum scale (x10)	Int 16 bits	1.00	
0072	P#033 (Ta-Td) in °C at 10V or 20mA (x10)	Int 16 bits	1.00	
0073	P#034 Max. (Ta-Td) in °C at 10V or 20mA (x10)	Int 16 bits	1.00	
0074	P#035 (Ta-Td) minimum range in °C for the analog output (x10)	Int 16 bits	1.00	
0075	P#036 Min. CO <sub>2</sub> (ppm) at analog output minimum scale	Int 16 bits	1.00	

Register number	Parameter	Format	From FW Ver.	Notes
0076	P#037 CO <sub>2</sub> (ppm) at analog output minimum scale	Int 16 bits	1.00	
0077	P#038 CO <sub>2</sub> (ppm) at 10V or 20mA	Int 16 bits	1.00	
0078	P#039 Max. CO <sub>2</sub> (ppm) at 10V or 20mA	Int 16 bits	1.00	
0079	P#040 CO <sub>2</sub> minimum range in ppm for the analog output	Int 16 bits	1.00	
0080	P#041 Relay mode in HD45 and CO <sub>2</sub> relay mode in HD46 with simplified mode disabled	8 bits (LSB)	1.00	(2)
0081	P#042 Temp. relay operation mode in HD46 with simplified mode disabled	8 bits (LSB)	1.00	(2)
0082	P#043 Humidity relay operation mode in HD46 with simplified mode disabled	8 bits (LSB)	1.00	(2)
0083	P#044 HD45 relay and HD46 CO <sub>2</sub> relay thresh. B	Int 16 bits	1.00	
0084	P#045 HD46 temp. relay threshold B	Int 16 bits	1.00	
0085	P#046 HD46 humidity relay threshold B	Int 16 bits	1.00	
0086	P#047 HD45 relay and HD46 CO <sub>2</sub> relay thresh. A	Int 16 bits	1.00	
0087	P#048 HD46 temp. relay threshold A	Int 16 bits	1.00	
0088	P#049 HD46 humidity relay threshold A	Int 16 bits	1.00	
0089	P#050 HD45 relay and HD46 CO <sub>2</sub> relay hysteresis (In HD45 models, it is the hysteresis when rotary switch is in position 0)	Int 16 bits	1.00	
0090	P#051 Temperature relay hysteresis in HD46	Int 16 bits	1.00	
0091	P#052 Humidity relay hysteresis in HD46	Int 16 bits	1.00	
0092	P#053 Relay assignment for HD45...R models	8 bits (LSB)	1.03	(2)
0093	P#054 Lower threshold (ppm) for HD45 BVR and HD45 BAR LED indicators	Int 16 bits	1.03	
0094	P#055 Medium threshold (ppm) for HD45 BVR and HD45 BAR LED indicators	Int 16 bits	1.03	
0095	P#056 Upper threshold (ppm) for HD45 BVR and HD45 BAR LED indicators	Int 16 bits	1.03	
0096	P#057 Threshold hysteresis (ppm) for HD45 BVR and HD45 BAR LED indicators	Int 16 bits	1.03	
0097	P#058 RS485 address	8 bits (LSB)	1.00	(2)
0098	P#059 RS485 Baud Rate	8 bits (LSB)	1.00	(2)
0099	P#060 RS485 transmission mode	8 bits (LSB)	1.00	(2)
0100	P#061 RS485 receiving mode	8 bits (LSB)	1.00	(2)
0101	P#082 Rotary switch threshold 1 with relay associated with temp. or humidity (x10)	Int 16 bits	1.07	
0102	P#083 Rotary switch 2 to 9 positions increment with relay associated with temperature or humidity (x10)	16 bit unsigned	1.07	
0103	P#084 Relay hysteresis with rotary switch in position other than 0 (x10 if associated with temperature or humidity)	16 bits unsigned	1.07	
0104	P#062 Relay mode in HD45 models with rotary switch in position other than 0.	8 bits (LSB)	1.07	(2)
0105	P#063 Relay simplified mode enabling in HD46 models	8 bits (LSB)	1.07	(2)
0106	P#064 CO <sub>2</sub> relay operation mode in HD46 with simplified mode enabled	8 bits (LSB)	1.07	(2)
0107	P#065 Temp. relay operation mode in HD46 models with simplified mode enabled	8 bits (LSB)	1.07	(2)



Register number	Parameter	Format	From FW Ver.	Notes
0108	P#066 Humidity relay operation mode in HD46 models with simplified mode enabled	8 bits (LSB)	1.07	(2)
0109	P#085 CO <sub>2</sub> relay threshold (ppm) in HD46 models with simplified mode enabled	Int 16 bits	1.07	
0110	P#086 Temp. relay threshold (X10) in HD46 models with simplified mode enabled	Int 16 bits	1.07	
0111	P#087 Humidity relay threshold (X10) in HD46 models with simplified mode enabled	Int 16 bits	1.07	
0112	P#088 Minimum possible threshold in ppm for CO <sub>2</sub> relay in HD46 models with simplified mode enabled	Int 16 bits	1.07	
0113	P#089 Minimum possible threshold (x10) for temperature relay in HD46 models with simplified mode enabled	Int 16 bits	1.07	
0114	P#090 Minimum possible threshold (x10) for humidity relay in HD46 models with simplified mode enabled	Int 16 bits	1.07	
0115	P#091 Maximum possible threshold in ppm for CO <sub>2</sub> relay in HD46 models with simplified mode enabled	Int 16 bits	1.07	
0116	P#092 Maximum possible threshold for temp. relay in HD46 models with simplified mode enabled	Int 16 bits	1.07	
0117	P#093 Maximum possible threshold for humidity relay in HD46 models with simplified mode enabled	Int 16 bits	1.07	
10001	Access code – character 1 (ASCII)	8 bits (LSB)	1.00	(2),(3)
10002	Access code – character 2 (ASCII)	8 bits (LSB)	1.00	(2),(3)
10003	Access code – character 3 (ASCII)	8 bits (LSB)	1.00	(2),(3)
10004	Access code – character 4 (ASCII)	8 bits (LSB)	1.00	(2),(3)
10005	Access code – character 5 (ASCII)	8 bits (LSB)	1.00	(2),(3)
10006	Access code – character 6 (ASCII)	8 bits (LSB)	1.00	(2),(3)

(1) Read only.

(2) "8 bits (LSB)" indicates register least significant byte.

(3) The reading of an access code register doesn't show the code character, but value 1, if the code is active, or value 0 if the code is inactive. In writing, registers are used only for the temporary storing of the characters sent by the user. Registers are not used to change the access code. It is not possible to change the access code stored in the instrument through RS485. The instrument verifies the access code correspondence after each written character.

Please note that the parameter address to be included in the command doesn't match the parameter number that appears in the menu of the instruments with keyboard or that can be set through USB connection, as it can be observed in the table above.

Please refer to Table 5.A. for the values that can be assigned to parameters.

If the request involves the reading of at least one parameter that is not included in Table 8.C, the instrument generates the following error message:

### Response

	Value	Length	Description
Function:	83h	1 byte	Error in parameters reading
Data:	02h	1 byte	Operation involved an inexistent parameter (Tab. 8.F at page 59)

Example:

Let's take into account an instrument having the following settings for the relative humidity analog output: 0V = 20.0% RH ; 10V = 80.0% RH.

From Table 8.C we obtain that the two parameters are stored in registers number 0061 and 0062, respectively. In order to read the two parameters values, the following shall be included in the request:

- address (= number - 1) of register with first parameter (0060 = 003Ch)
- number of parameters to be read (2 = 0002h).

Consequently, the command assumes the following format:

**Command**

	<b>Value</b>	<b>Length</b>	<b>Description</b>
<i>Function:</i>	03h	1 byte	Parameters reading command
<i>Data:</i>	00h	2 bytes	First parameter address (MSB)
	3Ch		First parameter address (LSB)
	00h	2 bytes	Number of parameters to be read (MSB)
	02h		Number of parameters to be read (LSB)

The instrument answers with the two parameter values:  $20.0\% \times 10 = 200 = 00C8h$   
 $80.0\% \times 10 = 800 = 0320h$

**Response**

	<b>Value</b>	<b>Length</b>	<b>Description</b>
<i>Function:</i>	03h	1 byte	Parameters reading command
<i>Data:</i>	04h	1 byte	Number of bytes for the values
	00h	2 bytes	RH% value at 0V (MSB)
	C8h		RH% value at 0V (LSB)
	03h	2 bytes	RH% value at 10V (MSB)
	20h		RH% value at 10V (LSB)

## **Measurements reading\_(function 04h)**

Function code 04h allows to read the values measured by the instrument.

The input register address containing the first quantity and the number of consecutive quantities to be read are indicated in the request data field.

Since, in the protocol, registers are numbered starting from 1, but data are addressed starting from 0, a register address is equal to the register number decremented by 1.

The instrument replies with the value of the requested quantities. It is not allowed to read quantities that are not measured by the instrument model.

Consequently, the *Function* and *Data* fields of command and response assume the following format:

### **Command**

	<b>Value</b>	<b>Length</b>	<b>Description</b>
<i>Function:</i>	04h	1 byte	Measurements reading command
<i>Data:</i>	0000h to FFFFh	2 bytes	First quantity address
	0001h to 007Dh	2 bytes	Number of quantities to be read ( <b>N</b> )

### **Response**

	<b>Value</b>	<b>Length</b>	<b>Description</b>
<i>Function:</i>	04h	1 byte	Measurements reading command
<i>Data:</i>	2 x <b>N</b>	1 byte	Number of bytes for the values
		2 x <b>N</b> bytes	Measurements values

A measurement value is stored in a 16-bit register and consequently always requires a 2-byte length. The most significant byte precedes the least significant one.

The following table lists the available quantities with their register number.

**Tab. 8.D: Input registers**

<b>Register number</b>	<b>Quantity</b>	<b>Format</b>	<b>From FW Ver.</b>	<b>Notes</b>
0001	Temperature in °C (x10)	16 bits	1.00	
0002	Temperature in °F (x10)	16 bits	1.00	
0003	Relative humidity in % (x10)	16 bits unsigned	1.00	
0004	Dewpoint in °C (x10)	16 bits unsigned	1.00	
0005	CO <sub>2</sub> in ppm	16 bits unsigned	1.00	

If the request involves the reading of at least one parameter that is not included in Table 8.D, the instrument will answer with the following error message:

### **Response**

	<b>Value</b>	<b>Length</b>	<b>Description</b>
<i>Function:</i>	84h	1 byte	Error in measurements reading
<i>Data:</i>	02h	1 byte	Operation involved an inexistent parameter (Tab. 8.F page 59)

Example:

You may want to read the relative humidity measurement of a transmitter whose current measure is 65.8%.

From Table 8.D we obtain that the relative humidity value is stored in register number 0003. In order to read the quantity value, you need to include in the request:

- address (= number - 1) of register with the first parameter (0002 = 0002h)
- number of parameters to be read (1 = 0001h).

Consequently, the command assumes the following format:

**Command**

	<b>Value</b>	<b>Length</b>	<b>Description</b>
<i>Function:</i>	04h	1 byte	Measurements reading command
<i>Data:</i>	00h	2 bytes	First quantity address (MSB)
	02h		First quantity address (LSB)
	00h	2 bytes	Number of quantities to be read (MSB)
	01h		Number of quantities to be read (LSB)

The instrument will answer with the measured value:  $65.8\% \times 10 = 658 = 0292h$

**Response**

	<b>Value</b>	<b>Length</b>	<b>Description</b>
<i>Function:</i>	04h	1 byte	Measurements reading command
<i>Data:</i>	02h	1 byte	Number of bytes for the values
	02h	2 bytes	Measured RH% value (MSB)
	92h		Measured RH% value (LSB)

### **Parameter storage** (function **05h**)

Function code 05h allows the permanent storage of any changes made to parameter values. **Parameter changes performed with Write functions (functions 06h and 10h) actually modify only values in the RAM memory and are therefore deleted in case of instrument power supply failure.**

Storage is associated with a number, as described in Table 8.E.

**Tab. 8.E: Storage command**

<b>Command number</b>	<b>Command</b>	<b>From FW Ver.</b>	<b>Notes</b>
0003	Parameter permanent storage	1.07	

The command address, followed by the fixed value FF00h is indicated in the request data field.

Since, in the protocol, registers are numbered starting from 1, but data are addressed starting from 0, a register address is equal to the register number decremented by 1.

The response format of the instrument is equal to the request format. Therefore, command and response *Function* and *Data* fields have the following format:

#### **Command**

	<b>Value</b>	<b>Length</b>	<b>Description</b>
<i>Function:</i>	05h	1 byte	Commands execution
<i>Data:</i>	0002h	2 bytes	Command address (= number - 1)
	FF00h	2 bytes	Fixed value

#### **Response**

	<b>Value</b>	<b>Length</b>	<b>Description</b>
<i>Function:</i>	05h	1 byte	Commands execution
<i>Data:</i>	0002h	2 bytes	Command address (= number - 1)
	FF00h	2 bytes	Fixed value

Only parameters changed within command transmission are permanently stored, any changes made afterwards require a new transmission of the command in order to make them become permanent.

The execution request of a command that is not present in table 8.E generates an error response from the instrument.

### **Changing a single configuration parameter** (function **06h**)

Function code 06h allows to change a single parameter value in the instrument.

The configuration register address containing the parameter to be changed and the new parameter value are indicated in the request data field.

Since, in the protocol, registers are numbered starting from 1, but data are addressed starting from 0, a register address is equal to the register number decremented by 1.

The response format of the instrument is equal to the request format. Therefore, command and response *Function* and *Data* fields have the following format:

## Command

	Value	Length	Description
<i>Function:</i>	06h	1 byte	Parameter write command
<i>Data:</i>	0000h to FFFFh	2 bytes	Parameter address
	0000h to FFFFh	2 bytes	New parameter value

## Response

	Value	Length	Description
<i>Function:</i>	06h	1 byte	Parameter write command
<i>Data:</i>	0000h to FFFFh	2 bytes	Parameter address
	0000h to FFFFh	2 bytes	New parameter value

A parameter value is stored in a 16-bit register and always requires, therefore, a 2-byte length. The most significant byte precedes the least significant one.

Table 8.C (page 46) lists all available parameters with their register number.

**The write 06h function changes only the value in the RAM memory, the change is therefore cancelled in case of power supply failure in the instrument.** To make any parameter changes permanent, the "Parameter permanent storage" command shall follow the parameter change (function 05h).

To change parameters protected by an access code, you must first write the code in the configuration registers from address 10000 to 10005. After changing the parameters, modify the content of the above mentioned registers to disable the code.

If the request involves writing a parameter not included in Table 8.C, the instrument replies with the following error message:

## Response

	Value	Length	Description
<i>Function:</i>	86h	1 byte	Error in parameter writing
<i>Data:</i>	02h	1 byte	Operation involved a non-existent parameter (Tab. 8.F page 59)

## **Changing several consecutive configuration parameters** (function 10h)

Function code 10h allows to change the value of several parameters with the same command, provided that parameters are included in consecutive registers.

The first configuration register address and the number of consecutive parameters to be changed, along with the number of bytes with the new values and the new parameter values are indicated in the request data field.

Since, in the protocol, registers are numbered starting from 1, but data are addressed starting from 0, a register address is equal to the register number decremented by 1.

The instrument response contains the address of the first modified register and the number of modified consecutive registers.

Therefore, command and Response *Function* and *Data* fields have the following format:

## Command

	Value	Length	Description
<i>Function:</i>	10h	1 byte	Parameters writing command
<i>Data:</i>	0000h to FFFFh	2 bytes	First parameter address
	0001h to 007Bh	2 bytes	Number of parameters to be changed ( <b>N</b> )
	2 x <b>N</b>	1 byte	Number of bytes
		2 x <b>N</b> bytes	New parameters values

## Response

	Value	Length	Description
<i>Function:</i>	10h	1 byte	Parameters writing command
<i>Data:</i>	0000h to FFFFh	2 bytes	First parameter address
	0001h to 007Bh	2 bytes	Number of changed parameters ( <b>N</b> )

A parameter value is stored in a 16-bit register and always requires, therefore, a 2-byte length. The most significant byte precedes the least significant one.

Table 8.C (page 46) lists all available parameters with their register number.

**The write function 10h changes only the value in the RAM memory; changes are therefore deleted in case of power supply failure in the instrument.** To make any parameter changes permanent, "Parameter permanent storage" command shall follow the parameter change (function 05h).

To change parameters protected by an access code, you must first write the code in the configuration registers from number 10000 to 10005. After changing the parameters, modify the content of the above mentioned registers to disable the code.

If the request involves entering a parameter not included in Table 8.C, the instrument replies with the following error message:

## Response

	Value	Length	Description
<i>Function:</i>	90h	1 byte	Error in parameters writing
<i>Data:</i>	02h	1 byte	Operation involved a non-existent parameter (Tab. 8.F page 59)

### Example:

Suppose you want to change CO<sub>2</sub> values corresponding to the initial and full scale values:

- 0V or 4mA = 350 ppm
- 10V or 20mA = 1200 ppm.

The two parameters are protected by the access code "240471".

In order to change the parameters, the access code has to be transmitted first by means of the command below:

## Command

	Value	Length	Description
<i>Function:</i>	10h	1 byte	Parameters write command
<i>Data:</i>	27h	2 bytes	Address of 1 <sup>st</sup> code char. (MSB)
	10h		Address of 1 <sup>st</sup> code char. (LSB)
	00h	2 bytes	6 parameters to be written (MSB)
	06h		6 parameters to be written (LSB)
	0Ch	1 bytes	12 bytes of values
	00h	2 bytes	1 <sup>st</sup> character value (MSB)
	02h		1 <sup>st</sup> character value (LSB)
	00h	2 bytes	2 <sup>nd</sup> character value (MSB)
	04h		2 <sup>nd</sup> character value (LSB)
	00h	2 bytes	3 <sup>rd</sup> character value (MSB)
	00h		3 <sup>rd</sup> character value (LSB)
	00h	2 bytes	4 <sup>th</sup> character value (MSB)
	04h		4 <sup>th</sup> character value (LSB)
	00h	2 bytes	5 <sup>th</sup> character value (MSB)
	07h		5 <sup>th</sup> character value (LSB)
	00h	2 bytes	6 <sup>th</sup> character value (MSB)
	01h		6 <sup>th</sup> character value (LSB)

The instrument replies by:

## Response

	Value	Length	Description
<i>Function:</i>	10h	1 byte	Parameters write command
<i>Data:</i>	27h	2 bytes	Address of the 1 <sup>st</sup> code char. (MSB)
	10h		Address of the 1 <sup>st</sup> code char. (LSB)
	00h	2 bytes	6 parameters written (MSB)
	06h		6 parameters written (LSB)

The instrument compares the written access code with the one stored in the internal memory; if they are equal, it allows parameter change.

From Table 8.C, we obtain that the initial and full scale values for the CO<sub>2</sub> analog output are stored in registers number 0076 and 0077 respectively. In order to write the two parameters values, the request will have to include:

- address (= number - 1) of 1<sup>st</sup> parameter register (0075 = 004Bh)
- number of parameters to change (2 = 0002h)
- number of bytes for the values (4 = 04h)
- values to be written (350 = 015Eh, 1200 = 04B0h)

Consequently, the command format will be:



## Command

	Value	Length	Description
Function:	10h	1 byte	Parameters write command
Data:	00h	2 bytes	Address of 1 <sup>st</sup> parameter(MSB)
	4Bh		Address of 1 <sup>st</sup> parameter (LSB)
	00h	2 bytes	Number of parameters to write (MSB)
	02h		Number of parameters to write (LSB)
	04h	1 byte	Number of bytes for the values
	01h	2 bytes	Value at 0V or 4mA = 350 ppm (MSB)
	5Eh		Value at 0V or 4mA = 350 ppm (LSB)
	04h	2 bytes	Value at 10V or 20mA = 1200 ppm (MSB)
	B0h		Value at 10V or 20mA = 1200 ppm (LSB)

The instrument will answer as follows:

## Response

	Value	Length	Description
Function:	10h	1 byte	Parameters write command
Data:	00h	2 bytes	Address of 1 <sup>st</sup> parameter (MSB)
	4Bh		Address of 1 <sup>st</sup> parameter (LSB)
	00h	2 bytes	Number of parameters to write (MSB)
	02h		Number of parameters to write (LSB)

For permanent storage of changes, transmit the command below:

## Command

	Value	Length	Description
Function:	05h	1 byte	Commands execution
Data:	0002h	2 bytes	Permanent storage command address
	FF00h	2 bytes	Fixed value

At the end, parameters can be protected again from undesired alterations by sending a different access code than the one stored in the internal memory.

## **Instrument error conditions** (function **07h**)

Function code 07h allows to read the 8-bit register containing information about any error conditions that may occur.

Each register bit corresponds to an error condition:

- *Bit 0*: humidity module EEPROM doesn't answer;
- *Bit 1*: humidity module EEPROM contains incorrect data;
- *Bit 2*: Relative humidity sensor calibration data not available;
- *Bit 3*: Calibration and configuration data memory is altered;
- *Bit 4*: Program memory altered;
- *Bit 5*: Temperature calibration error;
- *Bit 6*: Temperature measurement out of scale;
- *Bit 7*: Relative humidity measurement out of scale.

There is error condition if relevant bit is 1.

The command for the errors register reading is:

**Command**

	<b>Value</b>	<b>Length</b>	<b>Description</b>
<i>Function:</i>	07h	1 byte	Errors register reading command
<i>Data:</i>		0 byte	<i>Data</i> field is empty

The instrument answers as follows:

**Response**

	<b>Value</b>	<b>Length</b>	<b>Description</b>
<i>Function:</i>	07h	1 byte	Errors register reading command
<i>Data:</i>	00h to FFh	1 byte	Register value

**Instrument general information reading** (function **2Bh**)

Function code 2Bh allows to read the instrument basic general information, including:

- Manufacturer;
- Instrument model;
- Firmware version.

The command format will be as follows:

**Command**

	<b>Value</b>	<b>Length</b>	<b>Description</b>
<i>Function:</i>	2Bh	1 byte	Information reading command
<i>Data:</i>	0Eh	1 byte	Fixed value (MEI type - Modbus Encapsulated Interface)
	01h	1 byte	Fixed value (Identification type - basic)
	00h	1 byte	Fixed value (First information field)

The instrument will answer as follows:

**Response**

	<b>Value</b>	<b>Length</b>	<b>Description</b>
<i>Function:</i>	2Bh	1 byte	Information reading command
<i>Data:</i>	0Eh	1 byte	Fixed value (MEI type - Modbus Encapsulated Interface)
	01h	1 byte	Fixed value (Identification type - basic)
	01h	1 byte	Fixed value (Conformity level – basic – fields cannot be individually accessed)
<i>(continues...)</i>	00h	1 byte	Fixed value (No other fields available)

(continues...)

Value	Length	Description
00h	1 byte	Fixed value (next item ID)
03h	1 byte	Fixed value (Number of fields)
00h	1 byte	Fixed value (first field ID)
Length 1	1 byte	First field length
Value 1	(Length 1) bytes	First field value (Manufacturer)
01h	1 byte	Fixed value (second field ID)
Length 2	1 byte	Second field length
Value 2	(Length 2) bytes	Second field value (Model)
02h	1 byte	Fixed value (Third field ID)
Length 3	1 byte	Third field length
Value 3	(Length 3) byte	Third field value (Firmware version)

## **Error responses**

Commands correctly addressed and passing the CRC control can anyway generate error conditions, for example, if you try to read a non-existent parameter or if you ask the instrument to perform a function which is not compatible with the model.

In all cases where the instrument is not able to complete – for any reason – the requested action, a response is generated containing an error code. The value entered in the *Function* field corresponds to the received *Function* code with the most significant bit (MSB) set to 1, in order to inform the “Master” unit about either the error condition and the function that generated the error.

### **Response**

	Value	Length	Description
<i>Function:</i>	Requested function code with MSB=1	1 byte	Error in requested function execution
<i>Data:</i>	01h to 03h	1 byte	Error type (Table 8.F)

The table below describes the error codes:

**Tab. 8.F: Error codes**

Error code	Error	From FW Ver.	Notes
0001	Invalid function. The instrument doesn't manage the requested function.	1.00	
0002	Invalid address. At least one of the registers specified in the command does not exist.	1.00	
0003	Invalid data. Data length doesn't correspond to register length or value out of acceptable range.	1.00	

Further details relating to MODBUS protocol may be consulted at “[www.modbus.org](http://www.modbus.org)”.

## 9. TECHNICAL SPECIFICATIONS

### Sensor features

<b>Relative humidity RH</b> (for HD45 17..., HD46 17... and HD46 17B... models)	
Sensor	Capacitive
Measuring range	0...100 % RH -40...+85°C Dewpoint Td
Sensor operating range	-40...+80°C
Accuracy	±2.5% (0...85%RH)/±3.5% (85...100%RH) @ T=15...35°C and air speed < 0.25 m/s (*) (2.5 + 1.5% reading)% @ T= remaining range See table for Dewpoint
Resolution	0,1%
Temperature influence	2% over the whole temperature range
Hysteresis and repeatability	1% RH
Response time (T <sub>90</sub> )	<20 sec. (air speed = 2m/sec and constant temperature)
Long-term stability	1%/year

(\*) **The instruments are preset to operate in still air. To operate in circulating air (e.g. in a climatic room), the operating mode of the instruments must be changed (see the commands on pag. 39).**

<b>Temperature T</b> (for HD45 17..., HD45 7B..., HD46 17... and HD46 17B... models)	
Sensor type	NTC 10KΩ
Measuring range	-30...+85°C (-22...+185°F)
Accuracy (except models with current output)	±0.2°C ±0.15% of reading within 0...70°C ±0.3°C ±0.15% of reading within -30...0°C, 70...85°C
Accuracy (for models with current output)	±0.5°C ±0.15% of reading within -30...+85°C
Resolution	0.1°C
Response time (T <sub>90</sub> )	<30 sec. (air speed = 2m/sec)
Long-term stability	0.1°C/year

<b>Carbon Dioxide CO<sub>2</sub></b> (for HD45 7B..., HD45 B... and HD46 17B... models)	
Sensor	NDIR double wavelength
Range	0...5000 ppm
Sensor operating range	-5...50°C
Accuracy	±(50ppm+3% of reading) @ 20°C and 1013hPa
Resolution	1ppm
Temperature influence	0.1%f.s./°C
Response time (T <sub>90</sub> )	<120 sec. (air speed = 2m/sec and constant temperature )
Long-term stability	5% of measure/5 years

## Dewpoint Td accuracy (°C)

The dewpoint is a computed quantity that depends on relative humidity and temperature calibration accuracy. The values supplied below refer to  $\pm 2.5\%RH$ ,  $\pm 0.25^\circ C$ , 1013.25mbar accuracies.

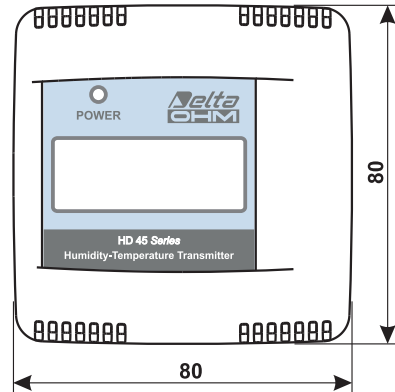
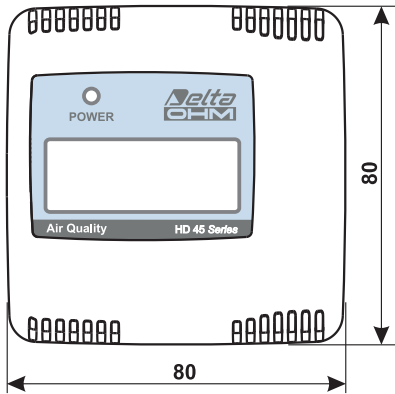
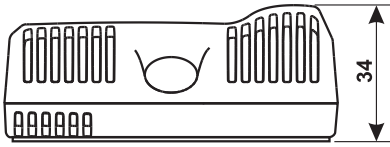
		Relative humidity (%)					
		10	30	50	70	90	100
Temperature °C	-20	2.50	1.00	0.71	0.58	--	--
	0	2.84	1.11	0.78	0.64	0.56	0.50
	20	3.34	1.32	0.92	0.75	0.64	0.62
	50	4.16	1.64	1.12	0.90	0.77	0.74
	100	5.28	2.07	1.42	1.13	0.97	0.91

## Instrument features

<b>Measuring frequency</b>	1 sample every 3 seconds
<b>Memory size</b>	2304 Records
<b>Logging interval</b>	Selectable between: 30s, 1m and 5m The stored values represent the average values of the samples acquired every 3 seconds in the selected logging interval.
<b>Serial outputs</b>	mini-USB (mini-USB / USB cable RS45 or RS45I cod.) RS485 MODBUS-RTU ( <i>HD45...S... and HD46...S... only</i> )
<b>Stored data security</b>	Unlimited
<b>Analog outputs</b>	0...10Vdc ( $R_L > 10k\Omega$ ) ( <i>HD45...V... and HD46...V only</i> ) 11Vdc out of range 4...20mA ( $R_{L\ MAX} = 400\Omega$ ) ( <i>HD45...A... and HD46...A only</i> ) 22mA outside the measuring range Active sourcing current output
<b>Relay outputs</b>	Bistable relay ( <i>HD45...R and HD46...R only</i> ) Contact: max 1A @ 30Vdc resistive load
<b>Power supply</b>	24Vac $\pm 10\%$ (50...60Hz) or 15...35Vdc
<b>Power consumption</b>	100 mW ( <i>except models with current output</i> ) 400 mW ( <i>for models with current output</i> )
<b>Stabilization time at switch-on</b>	15 minutes (to ensure declared accuracy)
<b>Instrument operating temperature</b>	0°C ... 50°C
<b>Operating relative humidity</b>	0%RH ... 95%RH non-condensing
<b>Dimensions (LxHxW)</b>	80 x 80 x 30 mm ( <i>HD45.17...</i> ) 80 x 80 x 34 mm ( <i>HD45.B... and HD45.7B...</i> ) 120 x 80 x 30 mm ( <i>HD46.17...</i> ) 120 x 80 x 34 mm ( <i>HD46.17B...</i> )
<b>Weight</b>	50 g
<b>Housing material</b>	ABS

**Dimensions** (in mm)

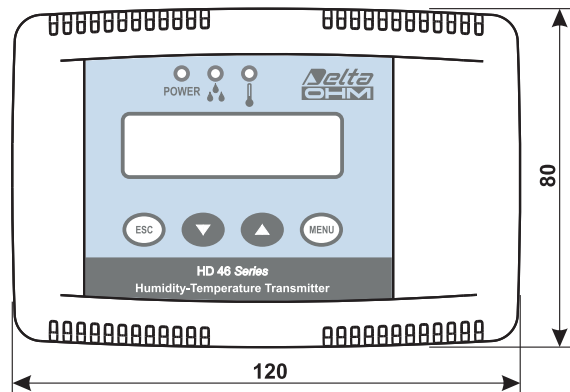
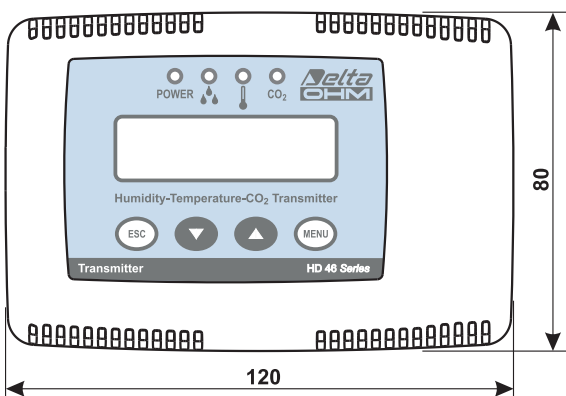
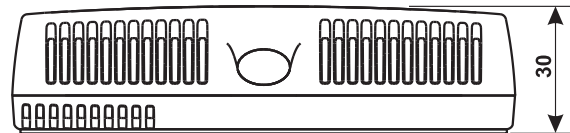
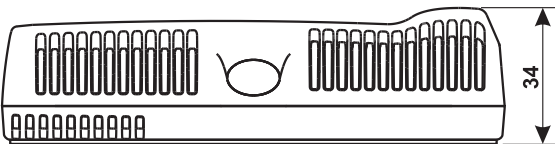
HD45... series



HD45 B...  
HD45 7B...

HD45 17...

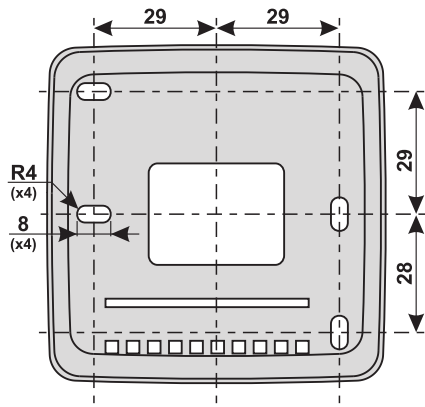
HD46... series



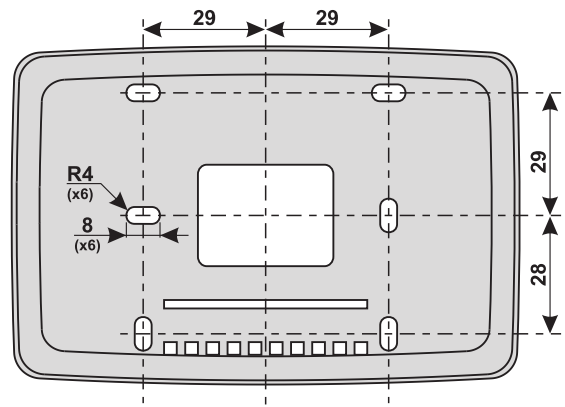
HD46 17B...

HD46 17...

## Fixing holes



HD45...



HD46...

## **Instrument storage conditions**

Temperature: -25...+70°C.

- Humidity: 10...90%RH non-condensing.
- In storing the instrument, avoid areas where:
  - There is a high humidity level.
  - The instrument is exposed to direct sunlight.
  - The instrument is exposed to a high temperature source.
  - There are high vibration levels.
  - There is presence of vapour, salt and/or corrosive gas.

## **Cleaning**

The instrument housing is in ABS plastic material: do not use solvents that are not compatible with cleaning purposes.

## **Authorized use**

Observe the technical specifications indicated in this chapter. Only the use and operation of this instrument in accordance with the instructions given in this manual are authorized. Any other use is to be considered as not authorized.

## **General safety instructions**

This instrument has been manufactured and tested in accordance with EN61010-1 safety directives for electronic measuring instruments and has left the factory in perfect safety technical conditions.

The instrument proper operation and operating safety can be ensured only if all standard safety measures as well as the specific measures described in this manual are followed.

The instrument proper operation and operating safety can be ensured only in the climatic conditions specified in this manual.

Do not use the instrument in places where there are:

- Rapid ambient temperature variations that may cause condensation.
- Corrosive or flammable gases.
- Direct vibrations or bumps to the instrument.
- High-intensity electromagnetic fields, static electricity.

If the instrument is moved from a cold place to a hot one, or vice versa, condensation formation can cause instrument malfunction. In this case, you will have to wait for the instrument temperature to reach ambient temperature level before turning the instrument on.

## **User obligations**

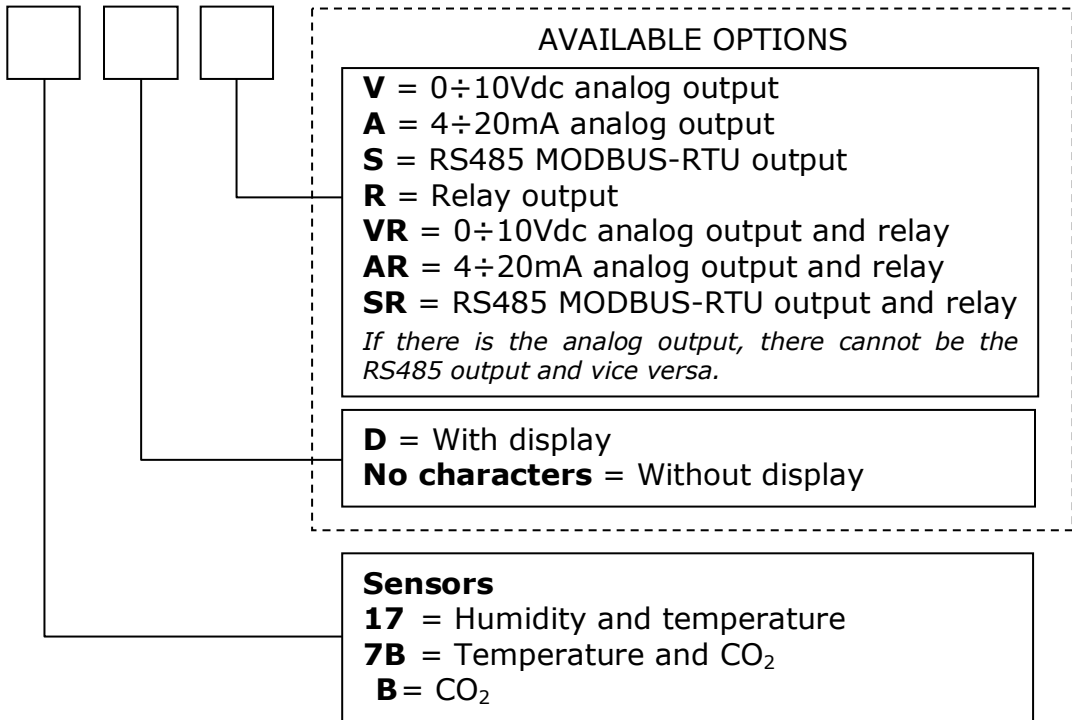
The instrument operator shall follow the directives and regulations below that refer to hazardous materials treatment :

- EEC directives on workplace safety
- National law regulations on workplace safety
- Accident prevention regulations

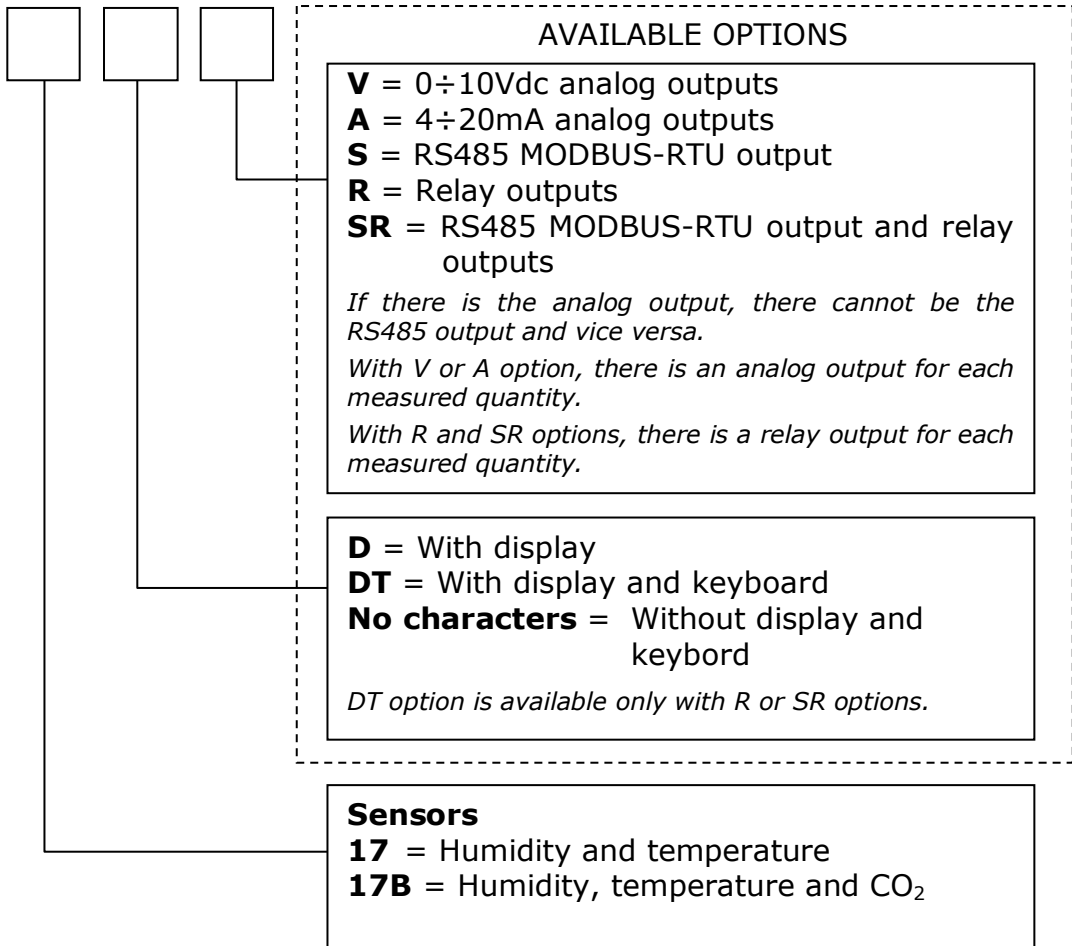


## 10. ORDERING CODES

**HD45**



**HD46**



### **Examples:**

**HD45 7BDVR:** Transmitter, indicator and regulator for temperature and CO<sub>2</sub>. With display, two 0÷10V analog outputs, a relay configurable for temperature or CO<sub>2</sub> control.

**HD45 BVR:** Transmitter, indicator and regulator for CO<sub>2</sub>. Without display, with CO<sub>2</sub> level LED indicators, with 0÷10V analog output and relay.

**HD45 17AR:** Transmitter and regulator for temperature and humidity. Without display, with two 4÷20mA analog outputs, a relay configurable for temperature or humidity control.

**HD45 17DV:** Transmitter and indicator for temperature and humidity. With display, two 0÷10V analog outputs, without relay.

**HD45 7BSR:** Transmitter and regulator for temperature and CO<sub>2</sub>. Without display, with RS485 output, without analog output, with a relay configurable for temperature or CO<sub>2</sub> control.

**HD46 17BDV:** Transmitter and indicator for temperature, humidity and CO<sub>2</sub>. With display, without keyboard, with three 0÷10V analog outputs, without relay and without RS485 output.

**HD46 17BDTSR:** Transmitter, indicator and regulator for temperature, humidity and CO<sub>2</sub>. With display and keyboard, with three relay outputs, with RS485 output.

**HD46 17S:** Temperature and humidity transmitter. Without display and keyboard, no relays, with RS485 output.

### **Accessories:**

**DeltaLog14:** Software for connection to a PC through serial port with mini-USB connector, instrument configuration and data download. For Windows<sup>®</sup> operating systems.

**HDM46:** Calibrated relative humidity and temperature replacement module (for HD46...models only).

**RS45:** Not isolated serial connection cable with built-in adapter. USB connector to PC and mini-USB connector to instrument serial port. The instrument is powered by the PC through the cable (at least a 500 mA USB port is required).

**RS45I:** Isolated serial connection cable with built-in adapter. USB connector to PC and mini-USB connector to instrument serial port. The instrument is not powered by the PC.

*Windows and Windows Vista are registered Microsoft Corporation trade marks.*

## APPENDIX A

### Control codes computing in MODBUS-RTU protocol

In MODBUS-RTU, two check modes for the transmitted data correctness coexist:

- Parity check on single byte
- Cyclic redundancy check (CRC) on the whole transmitted frame.

Codes are computed by the transmitting device as a function of the data to be transmitted. The receiving device calculates again the codes as a function of the received data and compares them with the ones attached to the message. If codes are correct, the message is accepted and processed.

#### **Parity check**

It is a check performed on a single byte.

A bit is added at the end of each information byte so that bit-1 total number is:

- even, if even parity is used
- odd, if odd parity is used

*Example:* byte = 1100 0101, bit-1 number is four. The parity bit will be 0 in case of even parity, or 1 if odd parity is used.

The protocol factory-default mode is even parity.

The instrument allows to edit or disable the parity check by means of the configuration parameter P#060.

#### **CRC code**

CRC code is a 16-bit binary value computed in function of all the message bytes and is attached at the end of the message to be transmitted.

The code computing procedure is as follows:

1. The 16 bits of the CRC register are all initialized to 1.
2. The exclusive OR (XOR) is performed between the CRC least significant byte and the first byte of the message (excluding start, parity and stop bits). The result becomes the new CRC value.
3. CRC register is shifted right by introducing a 0 on the left as the most significant bit.
4. The shifted out bit at right is checked: if it is 1, XOR is performed between CRC value and fixed value "1010 0000 0000 0001". The result is the new CRC value.
5. Steps 3 and 4 are repeated till a total of 8 shifts is achieved.
6. Steps 2, 3, 4 and 5 are repeated for all the message bytes.
7. The final CRC value is placed at the end of the message starting from the least significant byte, that will then be transmitted prior to the most significant one.

Example: CRC computation for the message formed by the two information bytes 0000 0010 (02h) and 0000 0111 (07h).

<i>CRC initialization (step 1)</i>	1111	1111	1111	1111	
<b>First information byte</b>			<u>0000</u>	<u>0010</u>	
<i>XOR computation (step 2)</i>	1111	1111	1111	1101	
<i>1<sup>st</sup> right shift (step 3)</i>	0111	1111	1111	1110	<b>1</b>
<i>Fixed value (1 is the shifted out bit)</i>	<u>1010</u>	<u>0000</u>	<u>0000</u>	<u>0001</u>	
<i>XOR computation (step 4)</i>	1101	1111	1111	1111	
<i>2<sup>nd</sup> right shift (step 3)</i>	0110	1111	1111	1111	<b>1</b>
<i>Fixed value (step 4, shifted out bit is 1)</i>	<u>1010</u>	<u>0000</u>	<u>0000</u>	<u>0001</u>	
<i>XOR Computation</i>	1100	1111	1111	1110	
<i>3<sup>rd</sup> right shift (step 3)</i>	0110	0111	1111	1111	<b>0</b>
<i>4<sup>th</sup> right shift (step 3)</i>	0011	0011	1111	1111	<b>1</b>
<i>Fixed value (step 4, shifted out bit is 1)</i>	<u>1010</u>	<u>0000</u>	<u>0000</u>	<u>0001</u>	
<i>XOR Computation</i>	1001	0011	1111	1110	
<i>5<sup>th</sup> right shift (step 3)</i>	0100	1001	1111	1111	<b>0</b>
<i>6<sup>th</sup> right shift (step 3)</i>	0010	0100	1111	1111	<b>1</b>
<i>Fixed value (step 4, shifted out bit is 1)</i>	<u>1010</u>	<u>0000</u>	<u>0000</u>	<u>0001</u>	
<i>XOR Computation</i>	1000	0100	1111	1110	
<i>7<sup>th</sup> right shift (step 3)</i>	0100	0010	0111	1111	<b>0</b>
<i>8<sup>th</sup> right shift (step 3)</i>	0010	0001	0011	1111	<b>1</b>
<i>Fixed value (step 4, shifted out bit is 1)</i>	<u>1010</u>	<u>0000</u>	<u>0000</u>	<u>0001</u>	
<i>XOR Computation</i>	1000	0001	0011	1110	
<b>Second information byte</b>			<u>0000</u>	<u>0111</u>	
<i>XOR Computation (step 2)</i>	1000	0001	0011	1001	
<i>1<sup>st</sup> right shift (step 3)</i>	0100	0000	1001	1100	<b>1</b>
<i>Fixed value (step 4, shifted out bit is 1)</i>	<u>1010</u>	<u>0000</u>	<u>0000</u>	<u>0001</u>	
<i>XOR Computation</i>	1110	0000	1001	1101	
<i>2<sup>nd</sup> right shift (step 3)</i>	0111	0000	0100	1110	<b>1</b>
<i>Fixed value (step 4, shifted out bit is 1)</i>	<u>1010</u>	<u>0000</u>	<u>0000</u>	<u>0001</u>	
<i>XOR Computation</i>	1101	0000	0100	1111	
<i>3<sup>rd</sup> right shift (step 3)</i>	0110	1000	0010	0111	<b>1</b>
<i>Fixed value (step 4, shifted out bit is 1)</i>	<u>1010</u>	<u>0000</u>	<u>0000</u>	<u>0001</u>	
<i>XOR Computation</i>	1100	1000	0010	0110	
<i>4<sup>th</sup> right shift (step 3)</i>	0110	0100	0001	0011	<b>0</b>
<i>5<sup>th</sup> right shift (step 3)</i>	0011	0010	0000	1001	<b>1</b>
<i>Fixed value (step 4, shifted out bit is 1)</i>	<u>1010</u>	<u>0000</u>	<u>0000</u>	<u>0001</u>	

<i>XOR Computation</i>	1001	0010	0000	1000		
<i>6<sup>th</sup> right shift (step 3)</i>	0100	1001	0000	0100		<b>0</b>
<i>7<sup>th</sup> right shift (step 3)</i>	0010	0100	1000	0100		<b>0</b>
<i>8<sup>th</sup> right shift (step 3)</i>	0001	0010	0100	0001		<b>0</b>

The final check code is CRC = 0001 0010 0100 0001 (1241h)

The least significant byte is 0100 0001 (41h) and is the first to be transmitted.

The most significant byte is 0001 0010 (12h) and is the last byte of the frame to be transmitted.

## TABLE OF CONTENTS

<b>1. INTRODUCTION</b>	<b>2</b>
1.1. Instruments versions available	4
<b>2. FRONT PANEL DESCRIPTION</b>	<b>6</b>
<b>3. INSTALLATION AND CONNECTION</b>	<b>8</b>
3.1. HD45... connection diagrams	10
3.2. HD46... connection diagrams	11
<b>4. OPERATION MODE</b>	<b>12</b>
4.1. Analog outputs	13
4.2. Relay outputs	13
4.3. LED indicators in HD45 BVR and HD45 BAR MODEL	21
4.4. Logging	21
4.5. Indicating a fault	22
<b>5. CONFIGURATION</b>	<b>23</b>
5.1. Authorization levels	24
5.2. Configuration through keyboard (HD46...DT... only)	25
<b>6. CALIBRATION</b>	<b>37</b>
6.1. Replacement of R.H. and temperature module (HD46...only)	37
6.2. CO2 sensor calibration	38
<b>7. COMMUNICATION PROTOCOL (mini-USB output)</b>	<b>39</b>
<b>8. RS485 COMMUNICATION</b>	<b>40</b>
8.1. MODBUS-RTU protocol	41
<b>9. TECHNICAL SPECIFICATIONS</b>	<b>60</b>
<b>10. ORDERING CODES</b>	<b>65</b>
<b>APPENDIX A – Check codes in MODBUS-RTU protocol</b>	<b>67</b>

**DICHIARAZIONE DI CONFORMITÀ UE  
EU DECLARATION OF CONFORMITY****Delta Ohm S.r.L. a socio unico – Via Marconi 5 – 35030 Caselle di Selvazzano – Padova – ITALY**Documento Nr. / Mese.Anno: **5089 / 01.2018**  
Document-No. / Month. Year :

Si dichiara con la presente, in qualità di produttore e sotto la propria responsabilità esclusiva, che i seguenti prodotti sono conformi ai requisiti di protezione definiti nelle direttive del Consiglio Europeo:

*We declare as manufacturer herewith under our sole responsibility that the following products are in compliance with the protection requirements defined in the European Council directives:*Codice prodotto: **Serie HD45... / HD46...**  
Product identifier :Descrizione prodotto: **Trasmettitori / regolatori di temperatura, umidità e CO<sub>2</sub>**  
Product description : **Temperature, humidity and CO<sub>2</sub> transmitters / regulators**I prodotti sono conformi alle seguenti Direttive Europee:  
*The products conform to following European Directives:*

Direttive / Directives	
2014/30/EU	Direttiva EMC / EMC Directive
2014/35/EU	Direttiva bassa tensione / Low Voltage Directive
2011/65/EU	RoHS / RoHS

Norme armonizzate applicate o riferimento a specifiche tecniche:  
*Applied harmonized standards or mentioned technical specifications:*

Norme armonizzate / Harmonized standards	
EN 61010-1:2010	Requisiti di sicurezza elettrica / Electrical safety requirements
EN 61326-1:2013	Requisiti EMC / EMC requirements
EN 50581:2012	RoHS / RoHS

Il produttore è responsabile per la dichiarazione rilasciata da:  
*The manufacturer is responsible for the declaration released by:*

Johannes Overhues

Amministratore delegato  
Chief Executive Officer

Caselle di Selvazzano, 22/01/2018

Questa dichiarazione certifica l'accordo con la legislazione armonizzata menzionata, non costituisce tuttavia garanzia delle caratteristiche.

*This declaration certifies the agreement with the harmonization legislation mentioned, contained however no warranty of characteristics.*

# GUARANTEE



Member of GHM GROUP

## TERMS OF GUARANTEE

All DELTA OHM instruments are subject to accurate testing, and are guaranteed for 24 months from the date of purchase. DELTA OHM will repair or replace free of charge the parts that, within the warranty period, shall be deemed non efficient according to its own judgement. Complete replacement is excluded and no damage claims are accepted. The DELTA OHM guarantee only covers instrument repair. The guarantee is void in case of incidental breakage during transport, negligence, misuse, connection to a different voltage than that required for the appliance by the operator. Finally, a product repaired or tampered by unauthorized third parties is excluded from the guarantee. The instrument shall be returned FREE OF SHIPMENT CHARGES to your dealer. The jurisdiction of Padua applies in any dispute.



The electrical and electronic equipment marked with this symbol cannot be disposed of in public landfills. According to the Directive 2011/65/EU, the european users of electrical and electronic equipment can return it to the dealer or manufacturer upon purchase of a new one. The illegal disposal of electrical and electronic equipment is punished with an administrative fine.

This guarantee must be sent together with the instrument to our service centre.

IMPORTANT: Guarantee is valid only if coupon has been correctly filled in all details.

**Instrument Code:**

**HD45**

**HD46**

Serial Number \_\_\_\_\_

## RENEWALS

Date \_\_\_\_\_

Date \_\_\_\_\_

Inspector \_\_\_\_\_

Inspector \_\_\_\_\_

Date \_\_\_\_\_

Date \_\_\_\_\_

Inspector \_\_\_\_\_

Inspector \_\_\_\_\_

Date \_\_\_\_\_

Date \_\_\_\_\_

Inspector \_\_\_\_\_

Inspector \_\_\_\_\_





The quality level of our instruments is the result of the constant development of the product. This may produce some differences between the information written in this manual and the instrument you have purchased. We cannot completely exclude the possibility of errors in the manual, for which we apologize.

The data, images and descriptions included in this manual cannot be legally asserted. We reserve the right to make changes and corrections with no prior notice.

**V2.4**  
**22/01/2018**